

**bn** BLACK NOVA





BLACK NOVA	5
ANY COLLECTION	10
ALBA COLLECTION	26
ARIA COLLECTION	40
TECHNICAL INFORMATION	67

## PEOPLE. PASSION. PURPOSE.

These three Pillars represent our essence, unrelenting drive and commitment.

We love pure design and innovative technology. We strive to craft the perfect blend of the two to deliver the best possible user experience across all senses and dimensions.

We design our keypads with a bold personality, premium materials and extreme attention to every single detail. Our mission is to deliver an exquisite and convenient device that nicely blends or stands out in any interior while addressing all users' needs and technology requirements.

Design, Innovation and R&D are the beating heart and inner soul of our group. We have dedicated professionals to challenge, improve and innovate every single aspect of our creation from shapes to ratios, colors to touch, materials to their combinations, and more.

Our ambition is to blend all these ingredients to create unique creations and have all our efforts seamlessly disappear into a pure and enchanted object, extremely intuitive and pleasing to use.



Designed in Italy

## FOR THOSE WHO SEEK EXCEPTIONAL DESIGNS

At Black Nova, we believe that details make the design, and pay extreme attention to materials, colors and shapes of our products. We aim to create an elegant keypad that can complement any interior design while providing a truly effortless and easy user experience.





## THE PERFECT MATCH

From eclectic urban loft to neoclassical hotel suite, from minimalist conference room to modern yacht's sky lounge, Black Nova keypads are the perfect match for any space and style.



RESIDENTIAL

Villas - Apartments



HOSPITALITY

Hotels - Resorts



MARINE

Yachts - Cruise Ships

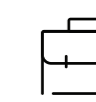

COMMERCIAL

Offices - Showrooms



## CREATIVE THOUGHT MEETS LATEST TECHNOLOGY

Black Nova keypads can seamlessly connect with a wide range of third-party systems, becoming the modern interface to control your stylish living environment. Our products are crafted using the newest technology with relentless passion to meet the most challenging requirements.





THE PURSUIT OF EXCELLENCE

ANY is a multipage smart keypad, created to surprise and delight users with its unique interaction experience and functions. Crafted with premium materials like marble, wood and crystal, ANY deserves a status of an avant-garde piece of art.









## ONE SWITCH, ANY FUNCTION, ANYWHERE

ANY allows you to navigate between control screens and access multiple room functions within one device. Control lights, temperature, media and automation scenes from an ANY switch that is close to you. No matter which room you are in, the entire living space control is right at your fingertips.



## SPECTACULAR EXPERIENCE

ANY welcomes you with a lambent light that shines through the panel's surface, taking the form of a swimming jellyfish, a flower in the wind or a geometric abstraction.



-   
 Gesture Sensor
-   
 Proximity Sensor
-   
 Light Sensor
-   
 841 LED RGB Matrix
-   
 Full Capacitive Touch Screen
-   
 Humidity Sensor
-   
 Temperature Sensor

### GESTURE RECOGNITION

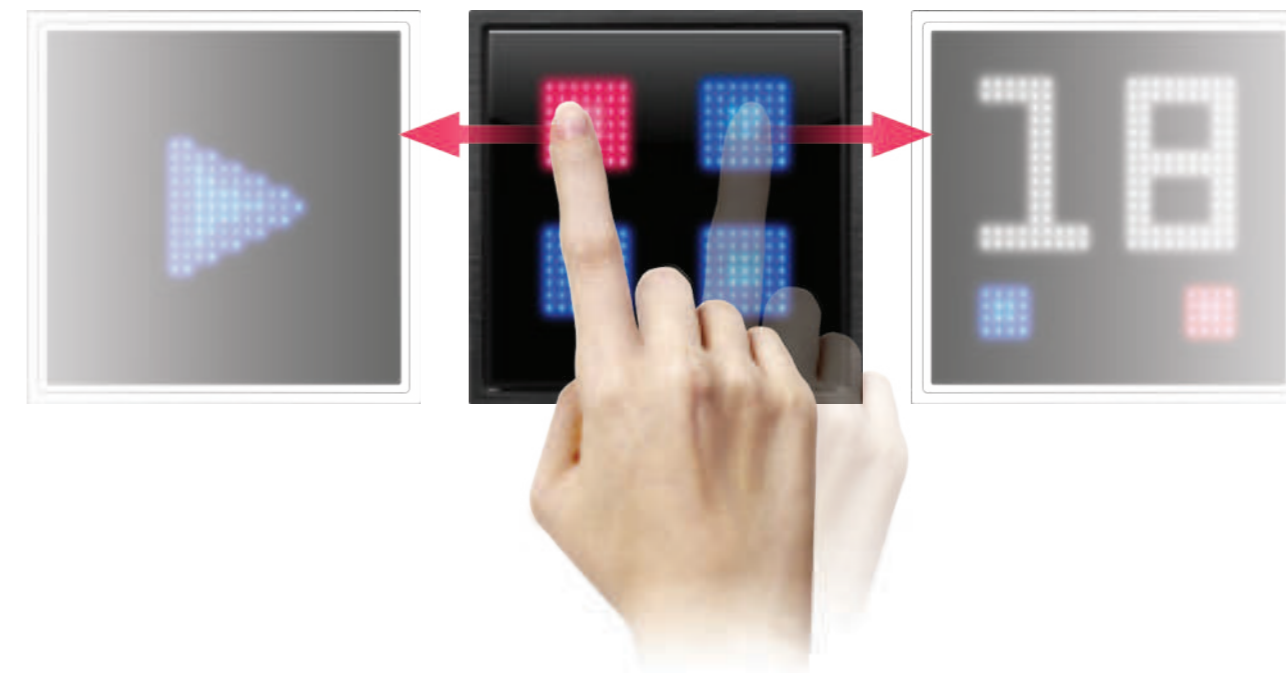

ANY recognizes the slightest movements of your hands without them even touching its surface. Gently wave your hand and hear the music volume going up. Move your hand down and see the room lights slowly dim.



ANY Glass Collection  
Ice White



ANY Glass Collection  
York Black

ANY Marble Collection  
White Marble



ANY Marble Collection  
Gold

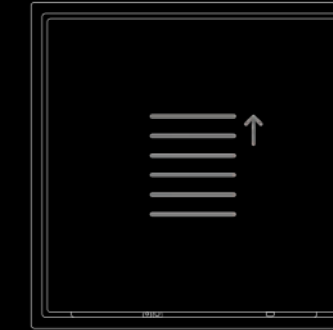
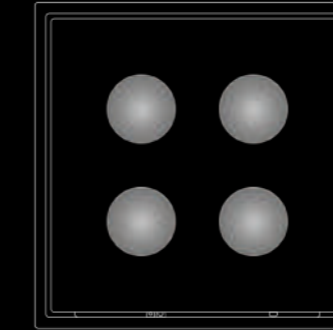
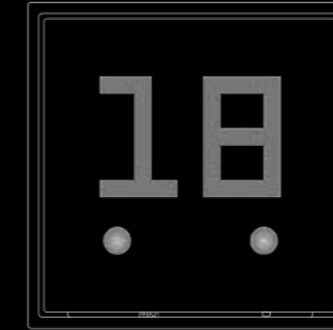

## ANY COLLECTION

ANY is available in two colors of glass with matching metal frame - Ice White and York Black. Premium finishes like marble and wood are available upon request. Displayed images and controls can be gently diffused to blend into your interior design or boldly sparkle to catch one's eye.

# ANY COLLECTION

Product dimensions

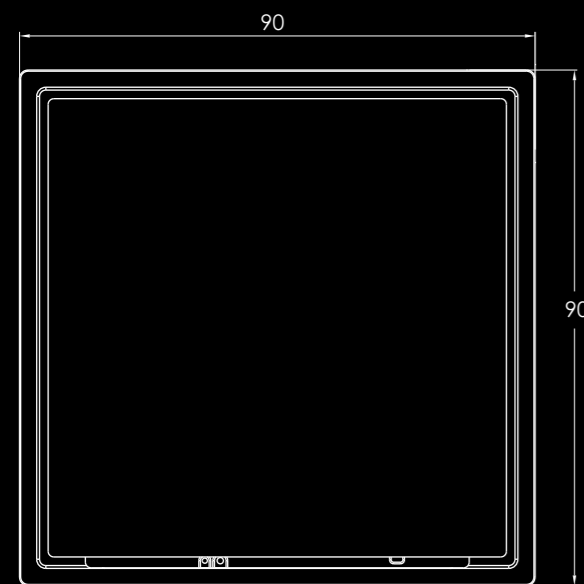

Front View



Side View

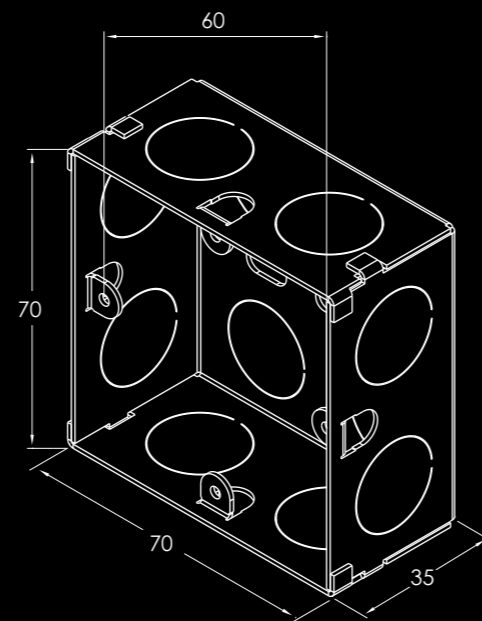

UK 3x3 Standard

Back Box

\* All dimensions are in mm

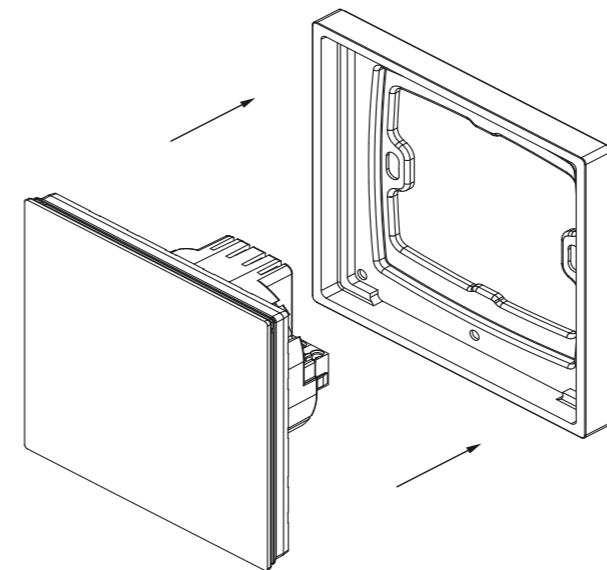

## EASY INSTALLATION AND MAINTENANCE

ANY is equipped with a snap-in magnetic bracket, that ensures easy and fast installation, maintenance and hot-swap replacement.

## BEAUTIFUL, YET POWERFUL

ANY is equipped with a bright LED matrix, capacitive touch screen and a handful of sensors to provide an unparalleled user experience and functionality.



# ALBA<sup>®</sup>

THE EPITOME OF ELEGANCE AND FUNCTIONALITY

ALBA's distinct look and bold combinations of metals and glass transform a keypad into an interior accent piece that you would want to showcase.



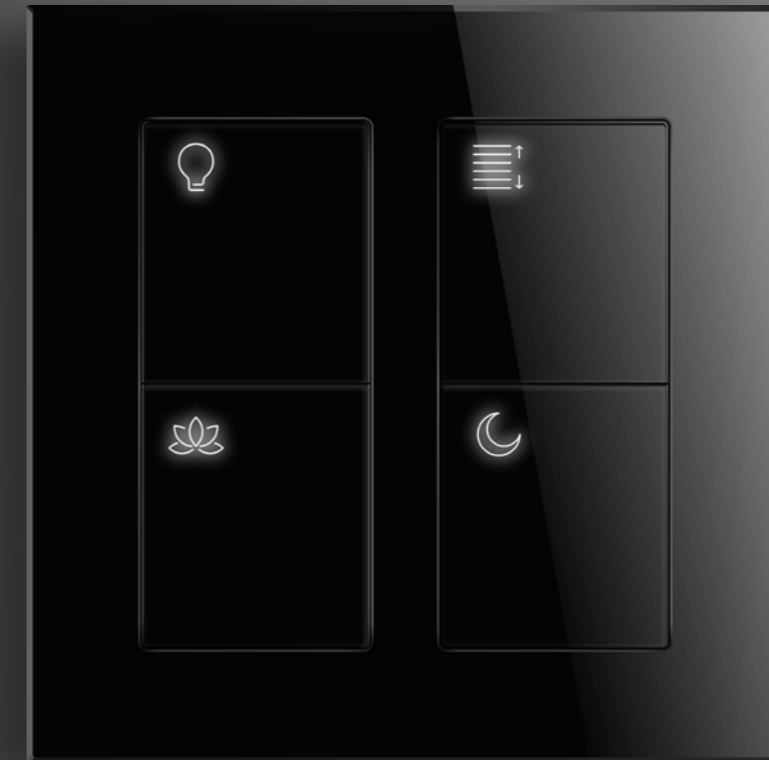





## WHEN MORE IS LESS

Black Nova keypads encompass multiple controls within the format of just one switch. Everything is right where you need it, materialized in a thin and elegant surface. More controls means less switches and more freedom to design a genuinely modern, minimalist space.

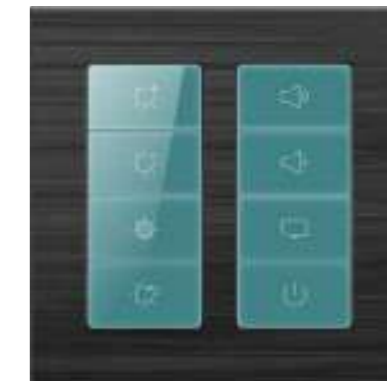
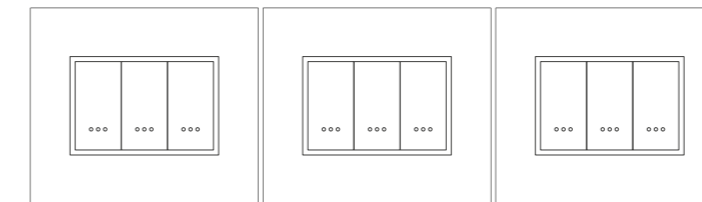



ALBA Glass Collection  
York Black



ALBA Metal Collection  
Mars Black



ALBA Metal Collection  
Silver



ALBA Glass Collection  
Ice White

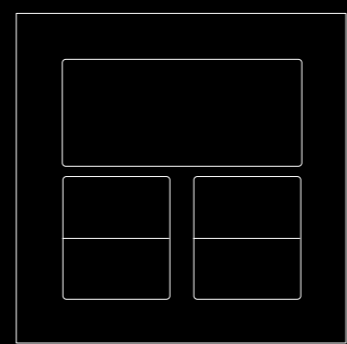

ALBA M1 Display

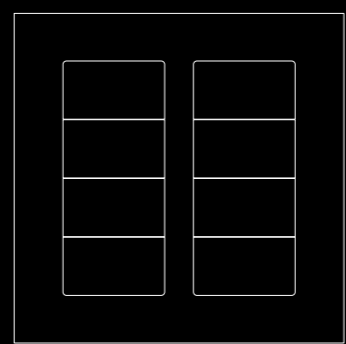

ALBA 8 Buttons

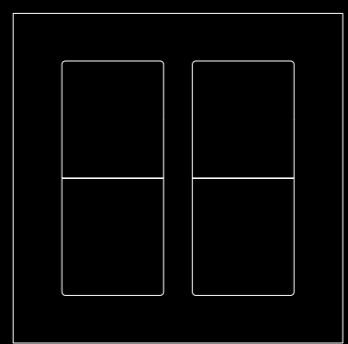

ALBA 4 Buttons

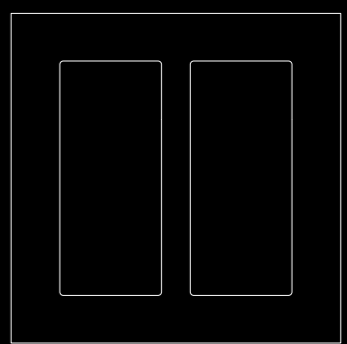

ALBA 2 Buttons

### ALBA COLLECTION

ALBA Collection is available in 2, 4 and 8 button configurations with up to 12 touch points. The ALBA M1 multipurpose display can support functions of thermostat, media or scenario control. Top and bottom buttons of the keypad can be equipped with 2 touch points each.

ALBA COLLECTION - Product dimensions

ALBA 2,4 and 8 Buttons

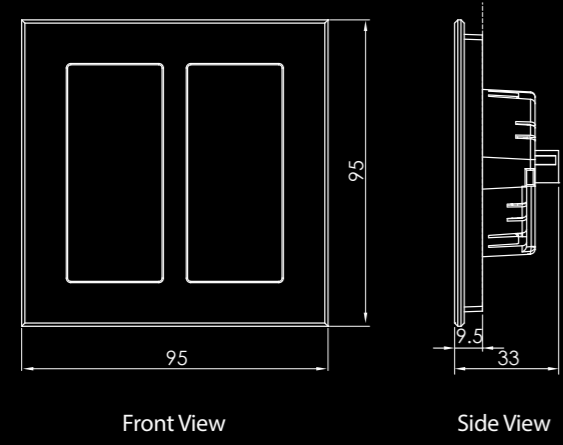

ALBA M1 Multipurpose Screen

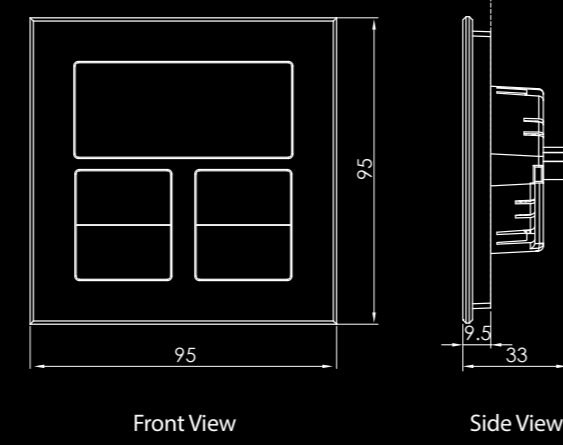

ALBA Keypad Buttons — Front View

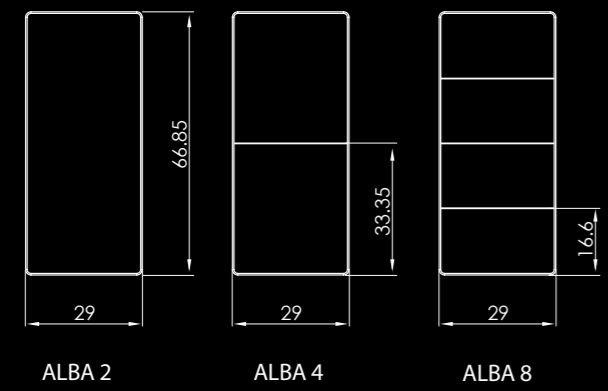

ALBA Collection Back Box

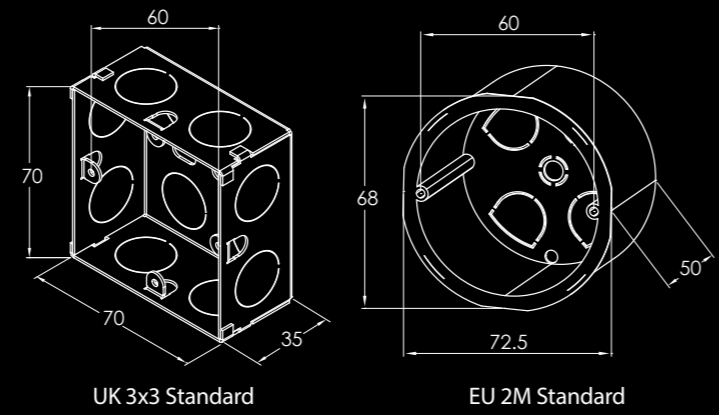

EFFORTLESS USER EXPERIENCE

Large buttons with engraved icons and text. All buttons evenly react to each press.  
A subtle click confirms every user touch.





## A KEYPAD TAILORED TO YOUR NEEDS

Customize Black Nova keypads to meet your desires. Design an unique interface by choosing icons from our Library and adding custom text in the preferred language. Create a keypad that perfectly matches your business operation and brand identity.

Try out our Online Keypad Configurator, available now at [www.blacknova.co](http://www.blacknova.co)

# ARIA®

A TRIBUTE TO MINIMALIST AESTHETICS

ARIA Collection elicit straight lines, pure shapes, and completely smooth surfaces. The natural simplicity of these glass keypads can complement any modern interior. ARIA is minimalist in its' essence.





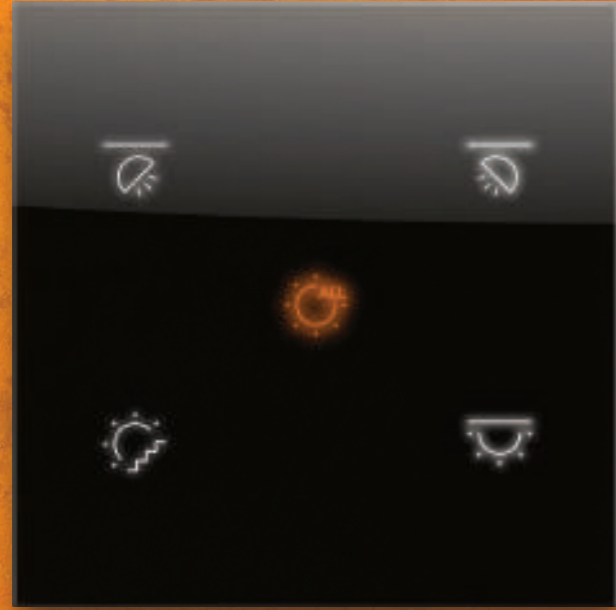

## SHINE WITH CHARACTER

Personalize your keypad even more by selecting color and intensity of each LED backlights. Choose from a 16.7 million color palette. The backlights dim when the keypad is not in use to ensure user's comfort during the night.

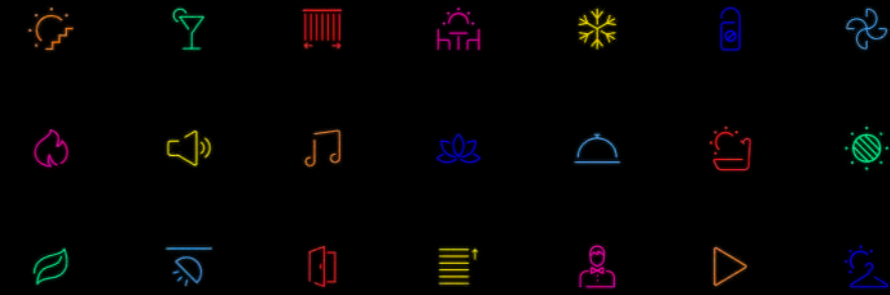





## TALK TO YOUR ROOM

ARIA T-DOT is a flawless interface that works with a powerful AI assistant controlled by your voice. Control lights and climate, play music, check news and weather, or call a taxi all hands free by simply asking T-DOT. The panel's speaker has 7 far-field microphones to hear you from anywhere in the room, even in the most noisy of environments.

 amazon alexa



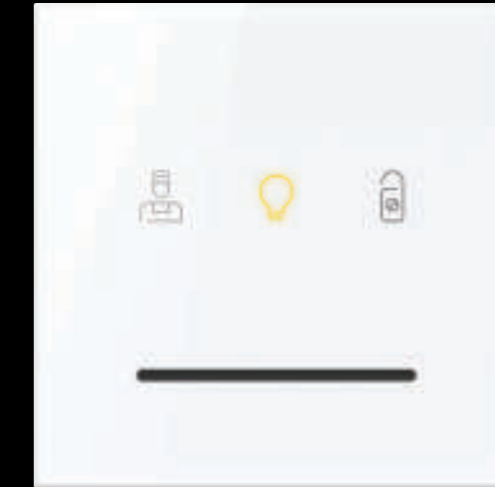

## ARIA HOSPITALITY COLLECTION

Improve service and operation efficiency with Black Nova keypads that completely match your hotel brand identity.



## A COMPLETE SOLUTION

Elegant door and card-holder keypads with room presence indicators create a complete solution for your hospitality business.

ARIA Glass Collection  
Ice White

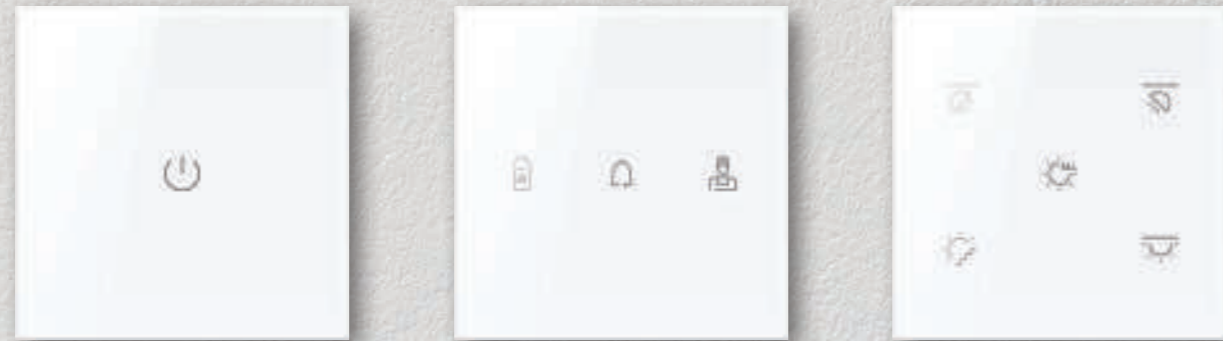

ALBA Glass Collection  
York Black

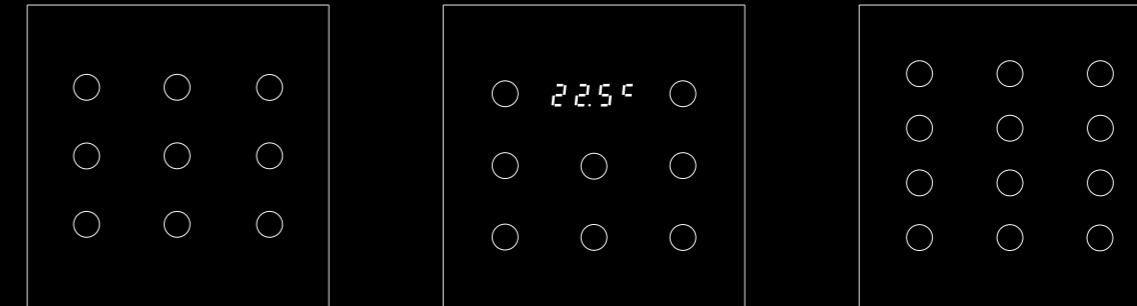

## ARIA COLLECTION

The ARIA Collection comes in 3x3 and 3x4 configurations with up to 12 touch-points and a thermostat version with a built-in temperature and humidity sensors. The keypads are available in two colors of extra clear glass - Ice White and York Black.

ARIA COLLECTION - Product dimensions

ARIA Hospitality  
Vertical Door Panel

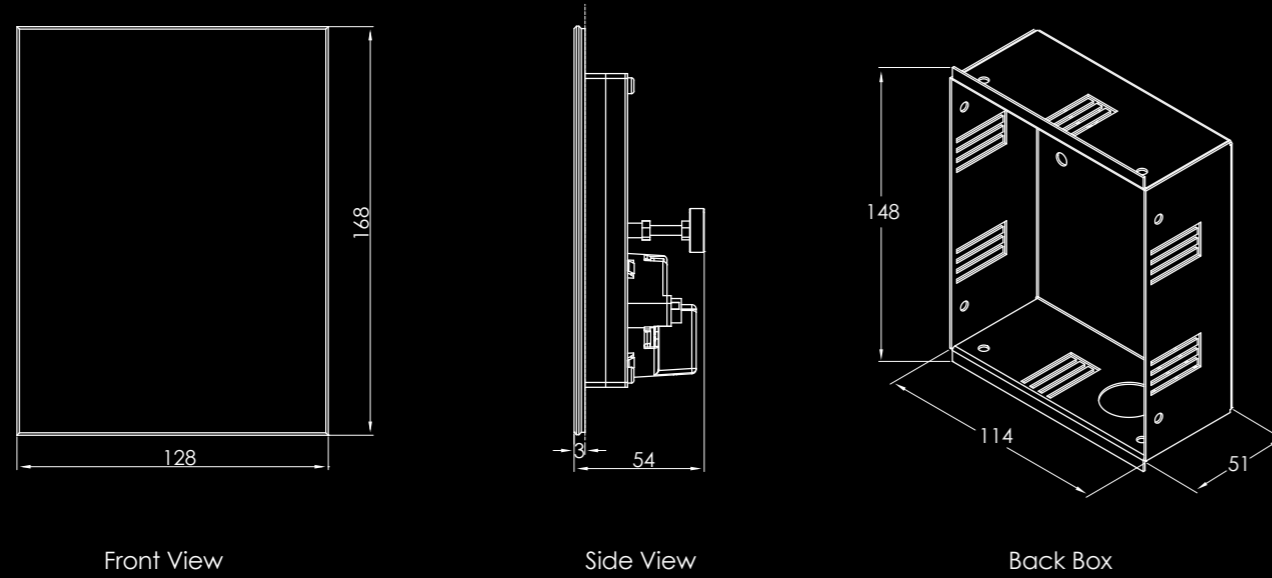

ARIA COLLECTION - Product dimensions

ARIA 3x3  
ARIA 3x4  
ARIA Thermostat

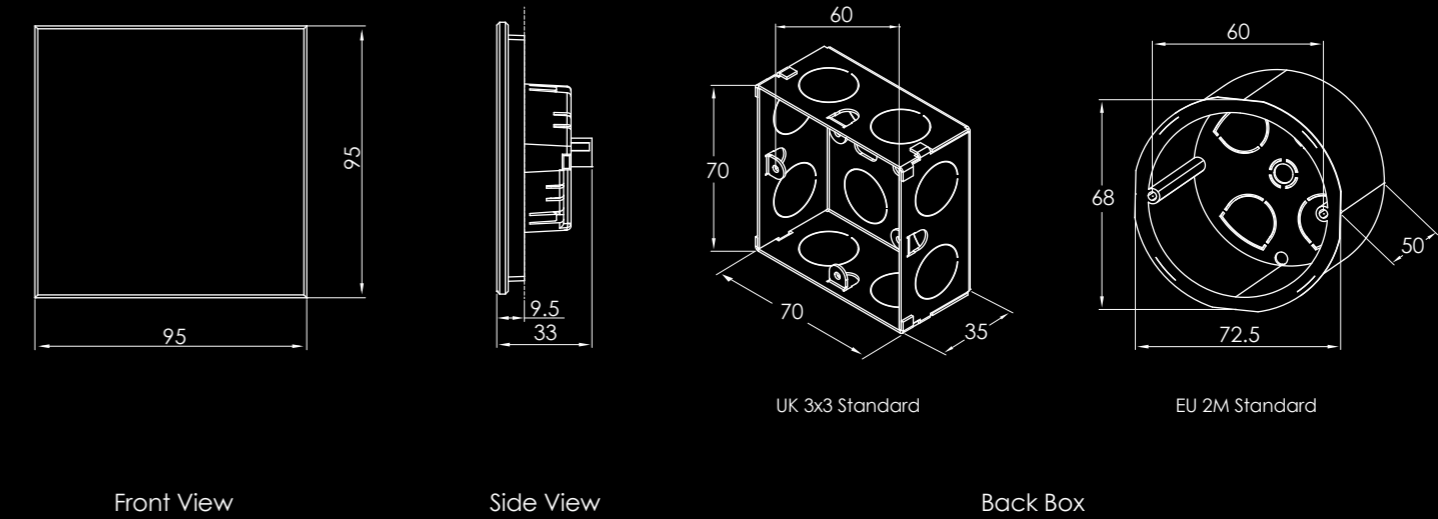

ARIA Hospitality  
Card-reader

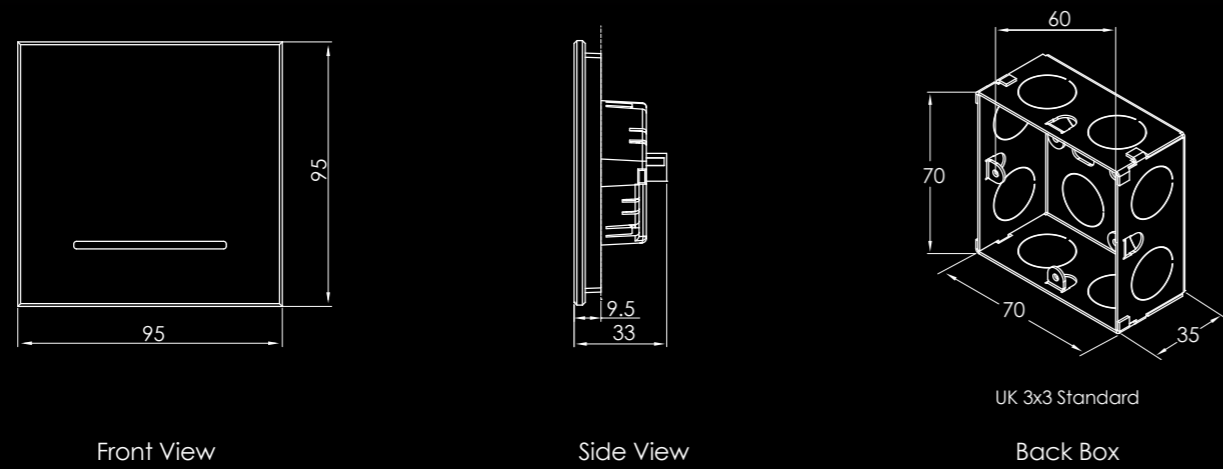

\* All dimensions are in mm

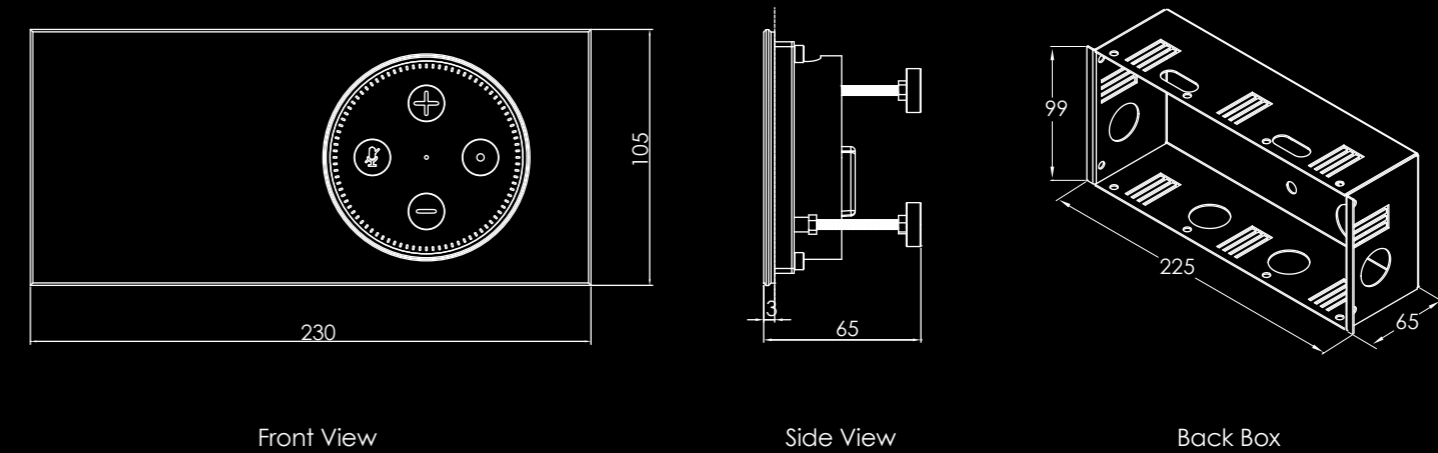

\* All dimensions are in mm



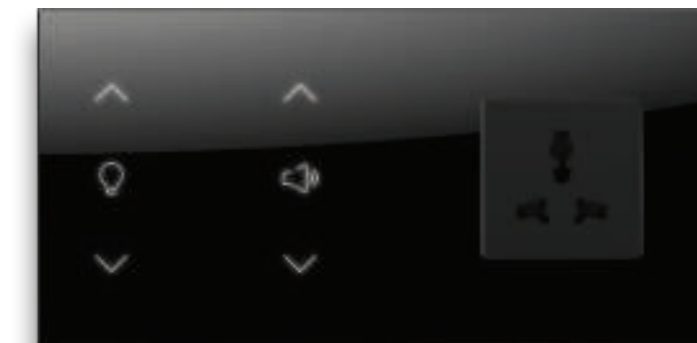
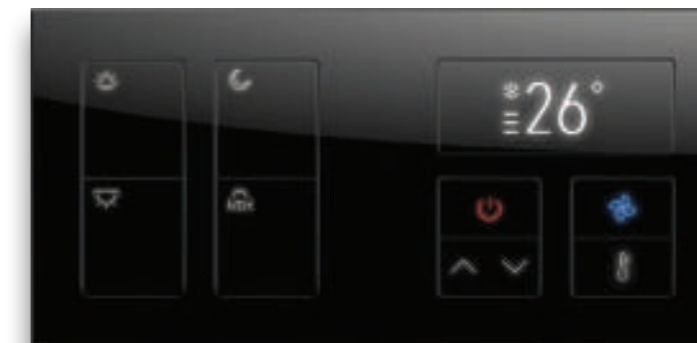

## GO BEYOND THE FORMAT

ALBA and ARIA double frames allow you to combine different keypad layouts together or to equip your keypads with a socket. Reduce visual clutter and fulfill needs of the most complex of projects.



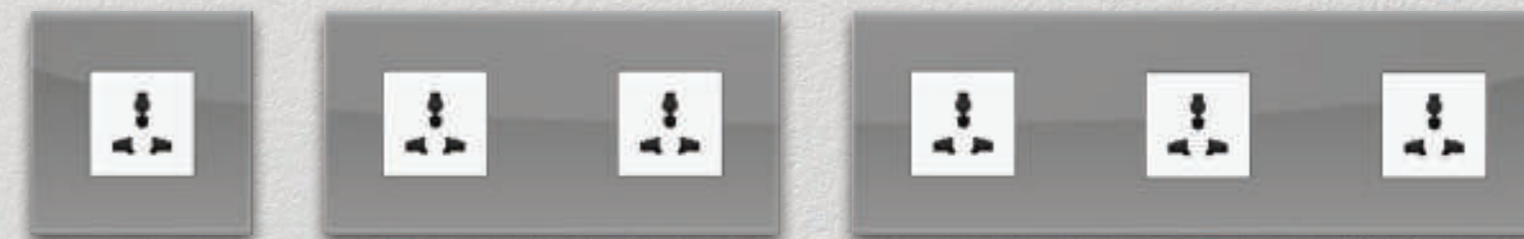

## SOCKET COLLECTION

Complete your design with socket frames, that perfectly match format and finishes of your ALBA and ARIA keypads.  
Frames are available in 1,2 and 3 modules versions.





TECHNICAL INFORMATION

## ANY COLLECTION

Product Name	ANY
Power Supply	KNX version: 30V DC, with auxiliary 20-30V DC power supply for LED Matrix Cresnet version: 24V DC ±10% RS-485 version: 24V DC ±10%
Power Supply Options	Via dedicated power supply only
Current Consumption	≤5W
Physical Interfaces	KNX TP or Cresnet
Communication Protocols	KNX or Cresnet
Temperature Sensor	Digital, 0.2 °C accuracy
Humidity Sensor	Digital, 0-100% range, 2% accuracy
Screen Type	29 x 29 LED Matrix
Max Quality of Buttons	-
Status Indicators	-
Presence Detection Sensor	Digital Infrared
Warm Up Time	10 seconds
Faceplate Options	Glass, Marble
Frame Options	Metal, Marble, Wood
Door Number	-
RFID Card Reader	-
Socket Options	-
Number of Sockets	-
Case Material	Plastic Body - PC Plastic Frame - ABS Metal Frame - Aluminium/Marble
Mounting	Snap-in magnetic and mechanical locking
Dimensions (H x W x D)	90 x 90 x 9.5 mm
Weight	200 g
Operating Temperature Range	0 °C – +45 °C
Operating Humidity Range	90% R.H. max – non-condensing
Storage and Transportation Temperature Range	-10 °C – +70 °C
Storage and Transportation Humidity Range	90% R.H. max – non-condensing
Protection Level	IP20

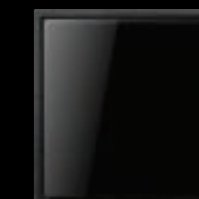

## ALBA COLLECTION



ALBA 2

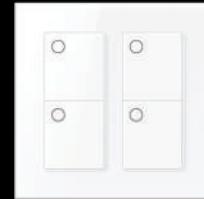

ALBA 4

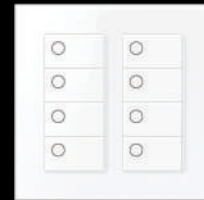

ALBA 8

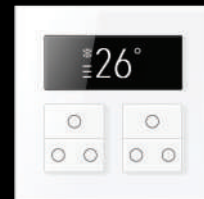

ALBA M1

Product Name	ALBA 2	ALBA 4	ALBA 8	ALBA M1
Power Supply	KNX version: 30V DC, with auxiliary 20-30V DC power supply for backlights Cresnet version: 24V DC ±10% RS-485 version: 24V DC ±10%			
Current Consumption	≤2W			
Physical Interfaces	KNX TP, RS-485 or Cresnet			
Communication Protocols	KNX, Modbus or Cresnet			
Temperature Sensor	NTC, 0.5 °C accuracy			
Humidity Sensor (if available)	-			Wide Range
Screen Type	-			7-segment, 4-digit display
Max Quantity of Buttons	2	4	8	4
Status Indicators / Backlight	Individually programmable backlight color and brightness (KNX version: auxiliary 20-30V DC power supply required)			
Warm Up Time	10 seconds			
Faceplate Options	Glass or Metal surface with Glass push buttons			
Socket Options	-			
Number of Sockets	-			
Case Material	PC			
Mounting	Snap-in magnetic and mechanical locking			
Dimensions (H x W x D)	195 x 95 x 8.5 mm			
Weight	307 g			
Operating Temperature Range	0 °C - +45 °C			
Operating Humidity Range	90% R.H. max – non-condensing			
Storage and Transportation Temperature Range	-10 °C – +70 °C			
Storage and Transportation Humidity Range	90% R.H. max – non-condensing			
Protection Level	IP20			

## ALBA COLLECTION



ALBA 2 S



ALBA 4 S



ALBA 8 S

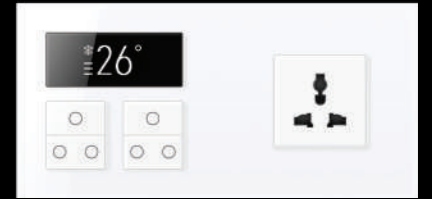

ALBA M1 S

Product Name	ALBA 2 S	ALBA 4 S	ALBA 8 S	ALBA M1 S
Power Supply	KNX version: 30V DC, with auxiliary 20-30V DC power supply for backlights Cresnet version: 24V DC ±10% RS-485 version: 24V DC ±10%			
Current Consumption	≤2W			
Physical Interfaces	KNX TP, RS-485 or Cresnet			
Communication Protocols	KNX, Modbus or Cresnet			
Temperature Sensor	NTC, 0.5 °C accuracy			
Humidity Sensor (if available)	-			Wide Range
Screen Type	-			OLED
Max Quantity of Buttons	2	4	8	4
Status Indicators / Backlight	Individually programmable backlight color and brightness (KNX version: auxiliary 20-30V DC power supply required)			
Warm Up Time	10 seconds			
Faceplate Options	Glass or Metal surface Glass push buttons			
Socket Options	UK Plug, UK Plug with switch+indicator, Universal Plug, Universal Plug with 2USB, Data+Phone, Single Data/Phone, Double Data/Phone, 2USB with indicator, Shaving Socket			
Number of Sockets	1			
Case Material	PC			
Mounting	Snap-in magnetic and mechanical locking			
Dimensions (H x W x D)	95 x 95 x 8.5 mm			
Weight	155 g			
Operating Temperature Range	0 °C - +45 °C			
Operating Humidity Range	90% R.H. max – non-condensing			
Storage and Transportation Temperature Range	-10 °C – +70 °C			
Storage and Transportation Humidity Range	90% R.H. max – non-condensing			
Protection Level	IP20			

## ARIA COLLECTION



ARIA 9



ARIA 12



ARIA TT

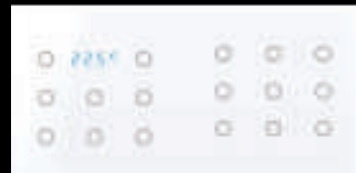

ARIA TT 9



ARIA TT 12

Product Name	ARIA 9	ARIA 12	ARIA TT	ARIA TT 9	ARIA TT 12
Power Supply	KNX version: 30V DC, with auxiliary 20-30V DC power supply for backlights Cresnet version: 24V DC ±10% RS-485 version: 24V DC ±10%				
Power Supply Options	-				
Current Consumption	≤2W			≤4W	
Physical Interfaces	KNX TP, RS-485 or Cresnet				
Communication Protocols	KNX, Modbus or Cresnet				
Temperature Sensor	NTC, 0.5 °C accuracy				
Humidity Sensor (if available)	-		Wide Range		
Screen Type	-		7-segment, 4-digit display		
Max Quantity of Buttons	9	12	10	19	22
Status Indicators / Backlight	Individually programmable backlight color and brightness (KNX version: auxiliary 20-30V DC power supply required)				
Warm Up Time	10 seconds				
Faceplate Options	Glass surface				
Socket Options	-				
Number of Sockets	-				
Case Material	PC				
Mounting	Snap-in magnetic and mechanical locking				
Dimensions (H x W x D)	95 x 95 x 9.5 mm			195 x 95 x 9.5 mm	
Weight	155 g			270 g	
Operating Temperature Range	0 °C - +45 °C				
Operating Humidity Range	90% R.H. max – non-condensing				
Storage and Transportation Temperature Range	-10 °C – +70 °C				
Storage and Transportation Humidity Range	90% R.H. max – non-condensing				
Protection Level	IP20				

## ARIA COLLECTION



ARIA 9 S

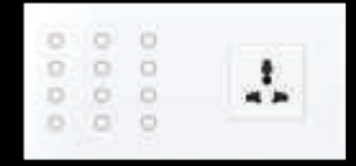

ARIA 12 S



ARIA T-DOT 9



ARIA T-DOT 12



ARIA T-DOT TT

Product Name	ARIA 9 S	ARIA 12 S	ARIA T-DOT 9	ARIA T-DOT 12	ARIA T-DOT TT
Power Supply	KNX version: 30V DC, with auxiliary 20-30V DC power supply for backlights Cresnet version: 24V DC ±10% RS-485 version: 24V DC ±10%				
Power Supply Options	-		Amazon Echo Dot v.2: 110/220V 50/60Hz		
Current Consumption	≤2W		≤2W excluding Amazon Echo Dot v.2		
Physical Interfaces	KNX TP, RS-485 or Cresnet		-		
Communication Protocols	Touch panel: KNX, Modbus or Cresnet		Touch panel: KNX, Modbus or Cresnet Amazon Echo Dot v.2: Bluetooth / WiFi 802.11 a, b, g, n (2.4 / 5 GHz)		
Temperature Sensor	NTC, 0.5 °C accuracy				
Humidity Sensor (if available)	-		-		Wide Range
Screen Type	-		-		7-segment, 4-digit display
Max Quantity of Buttons	9	12	9	12	10
Status Indicators / Backlight	Individually programmable backlight color and brightness (KNX version: auxiliary 20-30V DC power supply required)				
Warm Up Time	10 seconds		10 seconds excluding Amazon Echo Dot v.2		
Faceplate Options	Glass surface				
Socket Options	UK Plug, UK Plug with switch+indicator, Universal Plug, Universal Plug with 2USB, Data+Phone, Single Data/Phone, Double Data/Phone, 2USB with indicator, Shaving Socket		-		
Number of Sockets	1		-		
Case Material	PC		PC excluding Amazon Echo Dot v.2		
Mounting	Snap-in magnetic and mechanical locking		Snap-in magnetic		
Dimensions (H x W x D)	195 x 95 x 9.5 mm		230 x 105 x 4 mm		
Weight	270 g	319 g	490 g including Amazon Echo Dot v.2	490 g including Amazon Echo Dot v.2	490 g including Amazon Echo Dot v.2
Operating Temperature Range	0 °C - +45 °C				
Operating Humidity Range	90% R.H. max – non-condensing				
Storage and Transportation Temperature Range	-10 °C – +70 °C				
Storage and Transportation Humidity Range	90% R.H. max – non-condensing				
Protection Level	IP20				

## ARIA HOSPITALITY



ARIA 3



ARIA 3 -CH / -RF

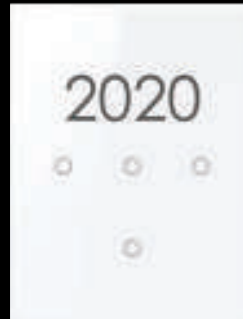

ARIA Door V / -RFID

Product Name	ARIA 3	ARIA 3 CH	ARIA 3 CH-RF	ARIA Door V	ARIA Door V-RFID
Power Supply	KNX version: 30V DC, with auxiliary 20-30V DC power supply for backlights Cresnet version: 24V DC ±10% RS-485 version: 24V DC ±10%				
Power Supply Options	-				
Current Consumption	≤2W				
Physical Interfaces	KNX TP, RS-485 or Cresnet				
Communication Protocols	KNX, Modbus or Cresnet				
Max Quantity of Buttons	3				
Status Indicators / Backlight	DND, MUR and Occupancy Individually programmable backlight color and brightness (KNX version: auxiliary 20-30V DC power supply required)	Individually programmable backlight color and brightness (KNX version: aux- iliary 20-30V DC power supply required)		DND, MUR and Occupancy Individually programmable backlight color and brightness (KNX version: auxiliary 20-30V DC power supply required)	
Warm Up Time	10 seconds				
Faceplate Options	Glass surface				
Door Number	-			Yes	
RFID Card Reader	-				
Case Material	-				
Mounting	Snap-in magnetic and mechanical locking			Snap-in magnetic	
Dimensions (H x W x D)	95 x 95 x 9.5 mm			168 x 128 x 4 mm	
Weight	155 g	150 g	155 g	600g	
Operating Temperature Range	0 °C - +45 °C				
Operating Humidity Range	90% R.H. max – non-condensing				
Storage and Transportation Temperature Range	-10 °C – +70 °C				
Storage and Transportation Humidity Range	90% R.H. max – non-condensing				
Protection Level	IP20				





DESIGNED BY BLACK NOVA IN ITALY

[blacknova.co](http://blacknova.co)

Selected images are provided by Sivak and Partners

All rights reserved - Black Nova Ltd. - 2020