



# Cloud-Managed Switches

MS-1212, MS-2400, MS-2416,  
MS-2424, MS-4424



QUICK START GUIDE

# Pakedge cloud-managed switch series

Pakedge's cloud-managed switches offer several models to fit size and power requirements for large or small networks. With key Layer 3 managed switch functionality, this series of switches is best suited for high-end multimedia and control applications.

## Regulatory compliance statement

**Note:** This equipment has been tested and found to comply with the limits for a Class B digital device. These limits are designed to provide reasonable protection against harmful interference in a residential installation.

**Caution:** Changes or modifications not expressly approved by Control4 Corporation could void the user's authority to operate the equipment. Shielded Cat 5e cable or better cables must be used in order to comply with the limits for a Class B digital device.

For the full regulatory compliance statement, see [www.pakedge.com/regulatory](http://www.pakedge.com/regulatory).

# Switch port overview

	Total ports	Ports with no PoE support	Ports with PoE+	Power budget	SFP+ ports
<b>MS-1212</b>	12	0	12	190W	(2) 10G ports
<b>MS-2400</b>	24	24	0	-	(2) 10G ports
<b>MS-2416</b>	24	8	16	245W	(2) 10G ports
<b>MS-2424</b>	24	0	24	370W	(2) 10G ports
<b>MS-4424</b>	44	20	24	370W	(4) 10G ports

For full specifications, see the product's information page on the Control4 Portal.

# Installing

## Tools required:

- Phillips screwdriver (if using rack-mount brackets)
- Computer with Ethernet interface and a modern web browser
- Ethernet cable
- *Optional:* A USB Micro-B adapter (not included) is necessary to use the console interface.

## To set up any of these switches:

- 1** Remove the switch from the box.
- 2** *Optional:* Install the rack-mount brackets. (See next pages for diagrams.)  
If mounting the switch in a standard 19" AV rack, attach the switch's rack-mount brackets. If not mounting to a rack, make sure that the switch is physically mounted near power and network connections (for example, a backbone switch or firewall/router).
- 3** Connect power to the switch.
- 4** Connect any port on the switch to your network where a DHCP server and the internet can be accessed. You are now ready to configure the switch with an IP address in your network range.

## Rack mount diagrams

MS-1212  
(1 unit per rack)

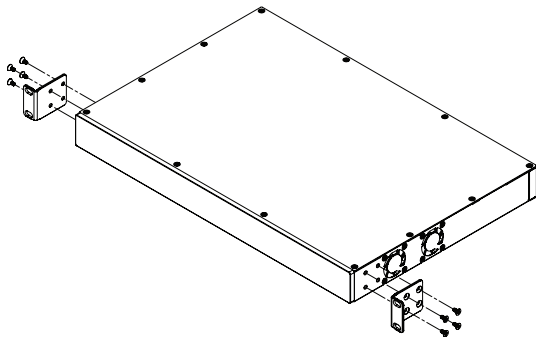
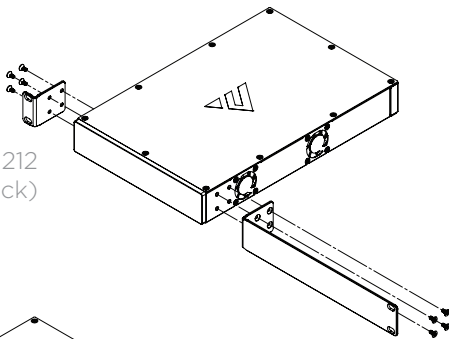

MS-2400, MS-2416,  
MS-2424, MS-4424  
(1 unit per rack)

MS-1212 (2 units per rack)

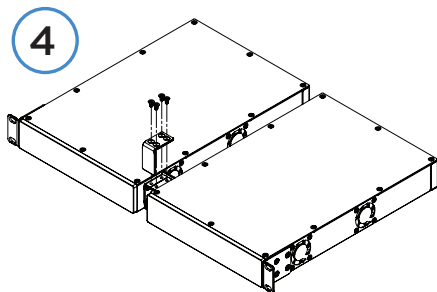
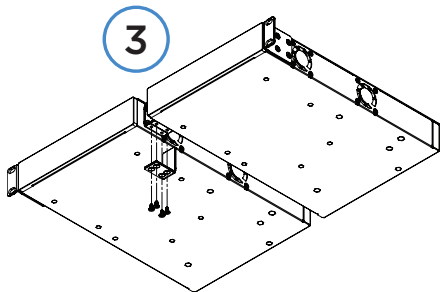
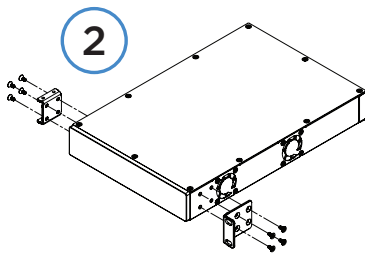
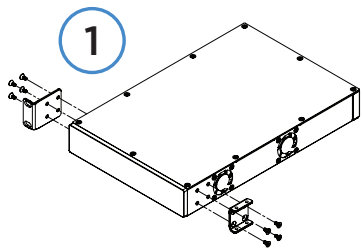

# Logging in through the network

You can log in to the switch's interface using a web browser on a computer that's connected to the network.

## To log in through the network:

- 1 Connect the managed switch to a power source. The **PWR** LED lights up and the fans power on.
- 2 Connect the switch to the network or directly to the router, then connect your computer to the same network.
- 3 Open the network router's interface to find the DHCP table, then look for the host name matching the model and MAC address of the switch and note the corresponding IP address.
- 4 In a web browser, enter the IP address you took note of in step 3.
- 5 Enter the username and password. (The default username is **admin** and the password is **password**.)

# Console into the switch

Pakedge MS Series switches have a USB Micro B console port that serves as an out-of-band management point of switch access. This can be useful when network access to the switch is not available. A USB console driver installed by your operating system may be required before you can access the console.

## To download and install the console driver:

- 1 Go to [pkdge.co/consoledriver](http://pkdge.co/consoledriver) .
- 2 Follow that page's instructions for downloading and installing the driver.

## To console into the switch:

- 1 Connect the console cable to the console port on the back of the switch, then connect the other end to your computer.
- 2 Open your chosen terminal emulator software (PuTTY, Terra Term, or Serial for MacOS), enter the COM port that your adapter is using, then set the following:

**Baud Rate: 115200**

**Character Size: 8**

**Parity Code: None**

**Stop Bits: 1**

**Flow Control: None**



## Resetting the IP address through the console

You can reset the switch's IP address through the console. This can be helpful in case of missconfiguration.

- 1 Console into the switch as described above.
- 2 Type “**show network**” and press **Enter** to see the current IP address and protocol mode.
- 3 To change the switch's network connection method, type “**network protocol**” and either “**dhcp**” or “**none**”.
- 4 To change the switch IP address, type “**network parms**” and then enter the <IP address>, <subnet mask>, and, optionally, the <default gateway> and press **Enter**.

The switch is now accessible from the newly configured IP address.

## Restoring factory defaults through the console

You can restore the switch's factory defaults through the console, if the switch it is not functioning properly.

- 1 Console into the switch as described above.
- 2 Type “**erase startup-config**” and press **Enter**.
- 3 Type “**reload**” and press **Enter**. The switch reboots and restores the factory default settings.
- 4 Type **copy running-config startup-config** to save your changes.





# Technical Support

For technical help:  
[www.pakedge.com/portal](http://www.pakedge.com/portal)  
[support@pakedge.com](mailto:support@pakedge.com)  
(650) 385-8703

For regulatory information:  
[www.pakedge.com/regulatory](http://www.pakedge.com/regulatory)



11734 S. Election Road  
Draper, UT 84020  
Main: (650) 385-8700 Fax: (650) 685-5520

[www.pakedge.com](http://www.pakedge.com)  
[sales@pakedge.com](mailto:sales@pakedge.com)

©2020 Wirepath Home Systems, LLC. All rights reserved.

Latest version at  
[pkdge.co/ms-qsg](http://pkdge.co/ms-qsg)



200-00647-B 2020-05-30 MS