

Panasonic®

Operating Instructions

Zoom Lens **Commercial Use**

Model No. **ET-C1T800**

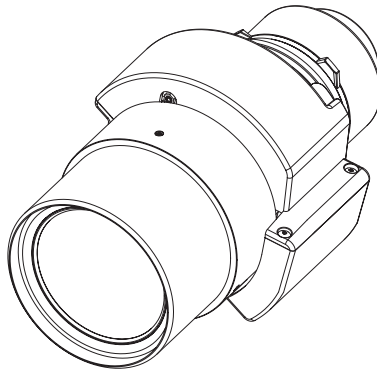

ENGLISH

FRANÇAIS

日本語

Thank you for purchasing this Panasonic product.

- To ensure correct use of this lens, please read the operating instructions supplied with the lens and the projector carefully.
- **Before using this product, be sure to read “Read this first!” (▶ Page 3 to 5).**
- Please save this manual for future use.

Contents

Read this first!	3
Before Use	6
Preparation	7
Before replacing the projection lens	7
Attaching the Lens.....	8
Detaching the Lens	8
Projection relationships	9
Lens shift ranges	12
Specifications	13
Dimensions	13
Projected image size and Projection distance	Appendix / Annexe / 付録 1

The “Appendix” can be found after the Japanese language section (**日本語**).

WARNING:

Do not look at or place your skin into the light emitted from the lens while the projector is being used.

Doing so can cause burns or loss of sight.

- Strong light is emitted from the projector's lens. Do not look at or place your hands directly into this light.
- Turn off the power when moving away from the projection lens or projector.

Do not project an image with the lens cover attached.

- Doing so can cause fire.

CAUTION:

Before replacing the projection lens, be sure to turn off the power and disconnect the power plug from the wall outlet.

- Unexpected projection of light may cause injury to eyes.
- Replacing the projection lens without removing the power plug may result in electric shock.

Do not stand in front of the lens while the projector is being used.

Doing so can cause damage and burns to clothing.

- Strong light is emitted from the projector's lens.

Do not place objects in front of the lens while the projector is being used.

Doing so can cause fire, damage to the object, or malfunction of the lens and projector.

- Strong light is emitted from the projector's lens.

Do not open the desiccant bag. Do not eat the contents.

Inadvertently ingesting desiccant could be harmful.

- If the desiccant gets into your eyes or mouth, immediately rinse with plenty of water and seek medical attention.
- Keep desiccant out of the reach of children.

Read this first! (continued)

■ Hazard distance (IEC/EN 62471-5:2015)

The distance from the projection lens surface, at which the emission reaches the Accessible Emission Limit (AEL) of risk group 2, is known as the hazard distance (HD) or safety distance. The area where the emission exceeds the Accessible Emission Limit of risk group 2 is called the hazard zone (HZ).

Within the hazard zone, never look into the light projected from the projector. The eyes may be damaged by direct irradiation even if you look at the light just for a moment. If you are outside the hazard zone, it is considered to be safe in all circumstances except deliberately staring into the light projected from the projector.

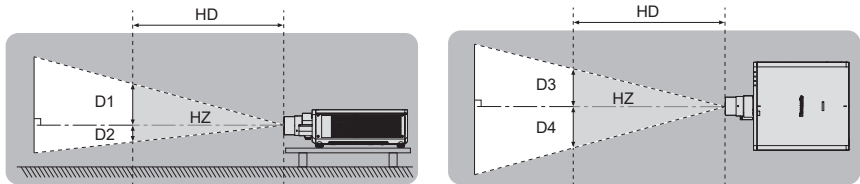

■ Risk group

The combination of the projector and the projection lens is categorized as risk group 2 when the hazard distance is 1 m (39-3/8") or less. It is categorized as risk group 3 when the hazard distance exceeds 1 m (39-3/8"), and it will be for professional use instead of consumer use.

In the case of risk group 3, there is a possibility of damaging the eyes by direct irradiation when looking into the projection light from inside the hazard zone even for a moment.

In the case of risk group 2, safe use without damaging the eyes is possible in all circumstances except deliberately staring into the light projected from the projector.

The risk group for the combination of the projection lens and a compatible projector is as follows.

Projector model	Risk group
PT-REQ15 / PT-REQ12 / PT-REQ10 / PT-REQ80 / PT-REZ15 / PT-REZ12 / PT-REZ10 / PT-REZ80	Risk group 3

Read this first! (continued)

Furthermore, each dimension to indicate the hazard area (Hz) for a combination with a projection lens that has a hazard distance exceeding 1 m (39-3/8") is as follows.

(Unit: m)

Projector model	HD*1	D1*2	D2*2	D3*2	D4*2
PT-REQ15 / PT-REZ15	4.2	0.435	0.435	0.500	0.500
PT-REQ12 / PT-REZ12	3.4	0.351	0.351	0.404	0.404
PT-REQ10 / PT-REQ80 / PT-REZ10 / PT-REZ80	3.2	0.331	0.331	0.380	0.380

*1 HD: Hazard distance

*2 The values of D1 to D4 will change in accordance with the lens shift amount. Each value in the table is the maximum value.

Note

- The values in the table are based on IEC/EN 62471-5:2015.
- The projectors compatible with each projection lens may be added or changed without notice. For the latest information, refer to the following website.
<https://docs.connect.panasonic.com/projector>

Attention

- If the light projected from the projector directly enters the eyes while you are inside the hazard zone, the retinas may be damaged. Do not enter the hazard zone during use. Alternatively, install the projector in a location where the projected light will not directly enter the eyes.

Before Use

Supported projectors

PT-REQ15 / PT-REQ12 / PT-REQ10 / PT-REQ80 / PT-REZ15 / PT-REZ12 / PT-REZ10 / PT-REZ80

Note

- This manual omits the alphabets at the end of projector model numbers.
- Models other than the above may also be supported. Refer to the operating instructions for your projector or the following website.
<https://docs.connect.panasonic.com/projector>

Supplied Accessories

Make sure that the following has been provided.

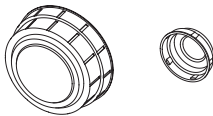
Part name	Appearance (quantity)
Lens cover	 <ul style="list-style-type: none">● The product is delivered with lens covers attached.● The shape and size of the lens covers are different for each product. <p style="text-align: right;">1 each for front and rear</p>

Preparation

Before replacing the projection lens

Return the projection lens to the home position before replacing or removing it. For details on how to return the lens to the home position, refer to the operating instructions of the projector.

Attention

- Make sure that the projector power supply is switched off before attaching or detaching the projection lens.
- After removing the projection lens, store it safely away from vibration or impacts.
- Do not touch the electric contact points of the projection lens with your fingers. Dust and dirt on the contacts may cause contact malfunctions, while static electricity may damage the unit.
- Do not turn the gear (ring) part of the projection lens barrel by hand. Doing so may damage the motor.
- Do not touch the surface of the lens with bare hands. Finger prints and dirt on the surface of the lens will be magnified by the lens and lower the quality of the projected image. Place the supplied lens cover on the zoom lens when the projector is not in use.
- The lens may become damaged by hitting with a hard object or by wiping the front surface of the lens with excessive force. Handle with care.
- Use a clean, soft and dry cloth to wipe away dust and dirt from the projection lens. Do not use fluffy cloths containing oil, water or dust for cleaning. The lens is easily damaged, so do not apply excessive pressure when wiping it.

Preparation (continued)

Attaching the Lens

Attention

- Before attaching the Projection Lens, remove the two lens covers attached to the Projection Lens.

The illustrations in this procedure depict use of the PT-REQ15 as an example.

- 1) **Align the protrusion mark on the projection lens with the protrusion mark on the main unit and insert it all the way (Fig. 1).**
 - Take care when inserting the lens not to damage the connector.
- 2) **Turn the projection lens clockwise (Fig. 2).**
 - If you turn the projection lens until it clicks into place, it will not come out even if turned counterclockwise. After turning the projection lens clockwise, turn it counterclockwise to confirm that it does not come out.

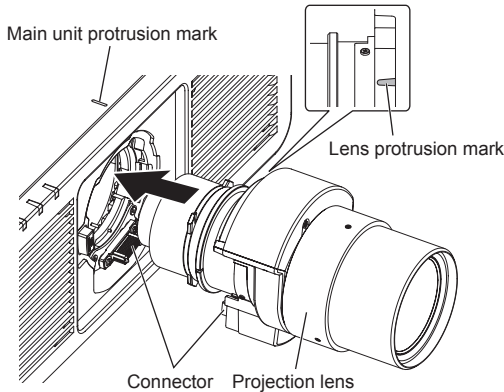

Fig. 1

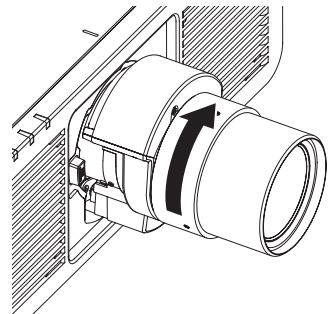
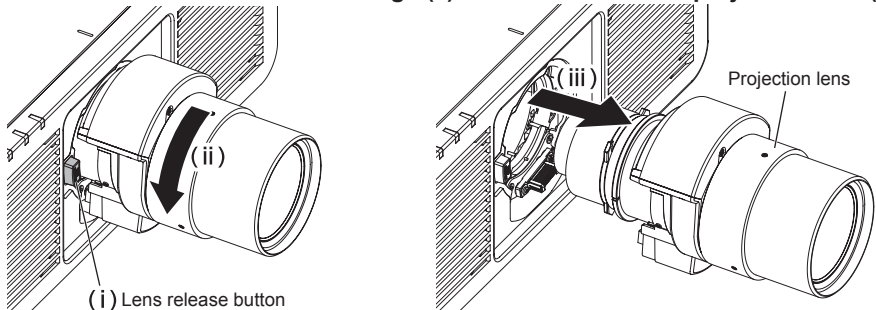

Fig. 2

Detaching the Lens

The illustrations in this procedure depict use of the PT-REQ15 as an example.

- 1) **While pressing the lens release button (i), turn the projection lens counterclockwise as far as it will go (ii) and then detach the projection lens (iii).**



Projection relationships

The dimensional relationship between the screen and the projector is shown below.

Dimensional relationship diagram

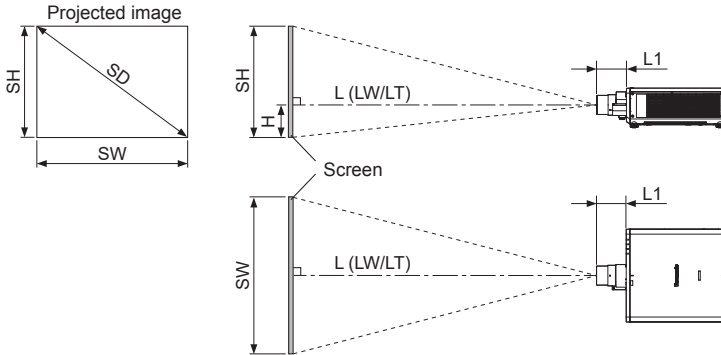

Note

- This diagram assumes that the size and position of the projected image will be adjusted so that the image fills the entire screen.
- This illustration is not drawn to scale.

L	Projection distance		H	Distance from the lens center to the lower edge of the projected image
	LW	Minimum distance	SH	Projected image height
	LT	Maximum distance	SW	Projected image width
L1	Lens protrusion dimension		SD	Projected image size

● Dimension for L1 (approximate values) (Unit: m)

Projector model	Dimension for L1 (approximate values)
PT-REQ15 / PT-REQ12 / PT-REQ10 / PT-REQ80 / PT-REZ15 / PT-REZ12 / PT-REZ10 / PT-REZ80	0.160

Note

- The illustrations of projectors in this manual are for informational purposes only and do not represent a specific projector model. Configurations may vary with the model.

Attention

- To prevent obstruction of the intake and exhaust vents, install the projector with a clearance from walls and objects. For details about the required distance from surrounding walls and objects, refer to the operating instructions for your projector.
If you are installing the projector in a sealed space, be sure to provide additional air conditioning equipment and ventilation equipment. Insufficient ventilation will result in an accumulation of heat and may activate the projector's protection circuit.
- Avoid setting up in places which are subject to sudden temperature changes, such as near an air conditioner or lighting equipment (studio lamps, etc.).

Projection relationships (continued)

Dimensional relationship

For details on the projection distance (L), refer to “Projected image size and Projection distance” and “Projection distance formulas” in the Appendix.

Note

- For details on “Projected image size and Projection distance” for projector models other than the following, refer to “Setting up” in the operating instructions of the projector.

PT-REQ15 / PT-REQ12 / PT-REQ10 / PT-REQ80 / PT-REZ15 / PT-REZ12 / PT-REZ10 / PT-REZ80

[GEOMETRY] projection range

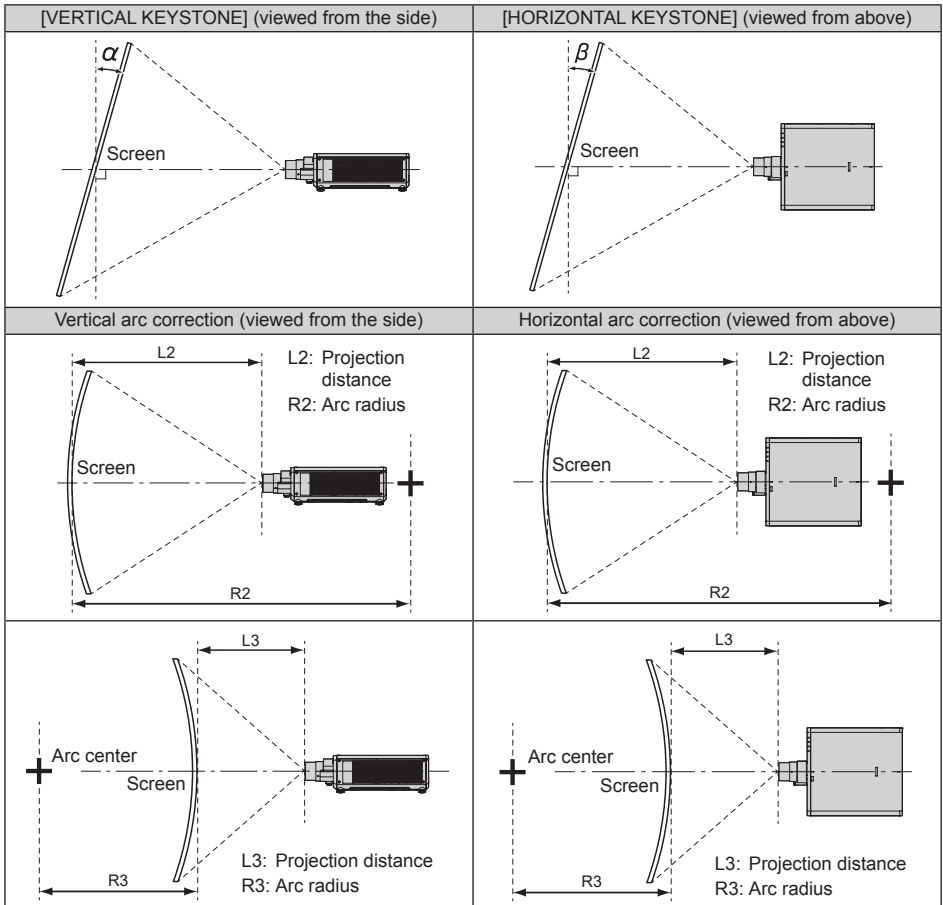

Projection relationships (continued)

Projector model	Only [KEYSTONE] used*1		[KEYSTONE] and [CURVED CORRECTION] used together				Only [CURVED CORRECTION] used	
	Vertical keystone correction angle α (°)	Horizontal keystone correction angle β (°)	Vertical keystone correction angle α (°)	Horizontal keystone correction angle β (°)	Min. value of R2/L2	Min. value of R3/L3	Min. value of R2/L2	Min. value of R3/L3
PT-REQ15 / PT-REQ12 / PT-REQ10 / PT-REQ80 / PT-REZ15 / PT-REZ12 / PT-REZ10 / PT-REZ80	±40	±40	±20	±15	0.5	1.0	0.3	0.6

*1 When [VERTICAL KEYSTONE] and [HORIZONTAL KEYSTONE] are used simultaneously, correction cannot be made exceeding total of 55°.

Note

- When [GEOMETRY] is used, the focus of the entire screen may be lost as correction increases.
- Make the curved screen a circular arc shape with one part of a perfect circle removed.
- Adjustment range of the [GEOMETRY] items may not match the listed projection range depending on the projection lens. Use this projector within the projection range, otherwise the correction may not work.

Lens shift ranges

Perform the lens position shift within the adjustment range.

Perform lens shift adjustment within the ranges shown in the following illustrations.

The focus may change when the lens position is shifted out of the adjustment range.

This is because the movement of the lens is restricted to protect the optical parts.

Projection position can be adjusted with the optical axis shift based on the home position in the respective range.

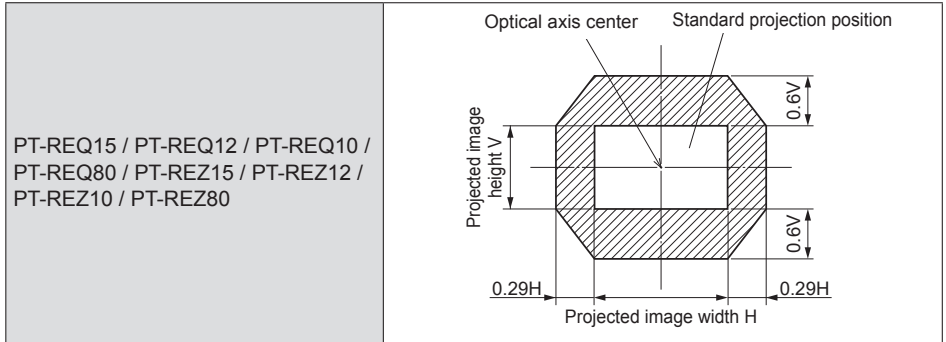

Note

- The home position of the projector is a point of origin position for the lens shift (i.e., vertical and horizontal positions of the lens) based on the results of lens calibration. It is not the optical center position of the screen.

Specifications

F Number	1.94 - 2.52
Focal Length (f)	58.3 mm (2-9/32") - 115.6 mm (4-9/16")
Dimensions	Width 135 mm (5-5/16") Height 148 mm (5-13/16") Depth 254 mm (10")
Net Weight	Approx. 2.4 kg (5.3 lb)

Dimensions

(Unit: mm)



■ Indication of the manufacturer and the importer with EU Directive requirements

<p>English</p>	<p>Manufactured by: Panasonic Connect Co., Ltd. 4-1-62 Minoshima, Hakata-ku, Fukuoka 812-8531, Japan Importer: Panasonic Connect Europe GmbH Hagenauer Strasse 43, 65203 Wiesbaden, Germany Authorized Representative in EU: Panasonic Connect Europe GmbH Panasonic Testing Centre Winsbergring 15, 22525 Hamburg, Germany</p>
<p>Български</p>	<p>Производител: Panasonic Connect Co., Ltd. 4-1-62 Minoshima, Hakata-ku, Fukuoka 812-8531, Япония Вносител: Panasonic Connect Europe GmbH Hagenauer Strasse 43, 65203 Wiesbaden, Германия Упълномощен представител в ЕС: Panasonic Connect Europe GmbH Panasonic Testing Centre Winsbergring 15, 22525 Hamburg, Германия</p>
<p>Čeština</p>	<p>Vyrobil: Panasonic Connect Co., Ltd. 4-1-62 Minoshima, Hakata-ku, Fukuoka 812-8531, Japonsko Dovozce: Panasonic Connect Europe GmbH Hagenauer Strasse 43, 65203 Wiesbaden, Německo Opřávněný zástupce v EU: Panasonic Connect Europe GmbH Panasonic Testing Centre Winsbergring 15, 22525 Hamburg, Německo</p>
<p>Српски</p>	<p>Произведен од: Panasonic Connect Co., Ltd. 4-1-62, Minoshima, Hakata-ku, Fukuoka 812-8531, Јапан Увозник: Panasonic Connect Europe GmbH Hagenauer Strasse 43, 65203 Wiesbaden, Немачка Овлашћени представник у ЕУ: Panasonic Connect Europe GmbH Panasonic Testing Centre Winsbergring 15, 22525 Hamburg, Немачка</p>
<p>Dansk</p>	<p>Fremstillet af: Panasonic Connect Co., Ltd. 4-1-62 Minoshima, Hakata-ku, Fukuoka 812-8531, Japan Importør: Panasonic Connect Europe GmbH Hagenauer Strasse 43, 65203 Wiesbaden, Tyskland Autoriseret repræsentant i EU: Panasonic Connect Europe GmbH Panasonic Testing Centre Winsbergring 15, 22525 Hamburg, Tyskland</p>
<p>Deutsch</p>	<p>Hergestellt von: Panasonic Connect Co., Ltd. 4-1-62 Minoshima, Hakata-ku, Fukuoka 812-8531, Japan Importeur: Panasonic Connect Europe GmbH Hagenauer Strasse 43, 65203 Wiesbaden, Deutschland Vertretungsberechtigter in der EU: Panasonic Connect Europe GmbH Panasonic Testing Centre Winsbergring 15, 22525 Hamburg, Deutschland</p>
<p>Eesti</p>	<p>Tootja: Panasonic Connect Co., Ltd. 4-1-62 Minoshima, Hakata-ku, Fukuoka 812-8531, Jaapan Maaletooja: Panasonic Connect Europe GmbH Hagenauer Strasse 43, 65203 Wiesbaden, Saksamaa Volitatud esindaja ELis: Panasonic Connect Europe GmbH Panasonic Testing Centre Winsbergring 15, 22525 Hamburg, Saksamaa</p>

Ελληνικά	<p>Κατασκευάστηκε από: Panasonic Connect Co., Ltd. 4-1-62 Minoshima, Hakata-ku, Fukuoka 812-8531, Ιαπωνία</p> <p>Εισαγωγέας: Panasonic Connect Europe GmbH Hagenauer Strasse 43, 65203 Wiesbaden, Γερμανία</p> <p>Εξουσιοδοτημένος αντιπρόσωπος στην ΕΕ: Panasonic Connect Europe GmbH Panasonic Testing Centre Winsbergring 15, 22525 Hamburg, Γερμανία</p>
Español	<p>Fabricado por: Panasonic Connect Co., Ltd. 4-1-62 Minoshima, Hakata-ku, Fukuoka 812-8531, Japón</p> <p>Importador: Panasonic Connect Europe GmbH Hagenauer Strasse 43, 65203 Wiesbaden, Alemania</p> <p>Representante Autorizado para la UE: Panasonic Connect Europe GmbH Panasonic Testing Centre Winsbergring 15, 22525 Hamburgo, Alemania</p>
Français	<p>Fabriqué par : Panasonic Connect Co., Ltd. 4-1-62 Minoshima, Hakata-ku, Fukuoka 812-8531, Japon</p> <p>Importateur : Panasonic Connect Europe GmbH Hagenauer Strasse 43, 65203 Wiesbaden, Allemagne</p> <p>Représentant autorisé dans l'UE : Panasonic Connect Europe GmbH Panasonic Testing Centre Winsbergring 15, 22525 Hambourg, Allemagne</p>
Gaeilge	<p>Arna dhéanamh ag : Panasonic Connect Co., Teo. 4-1-62 Minoshima, Hakata-ku, Fukuoka 812-8531, An tSeapáin</p> <p>Allmhaireoir : Panasonic Connect Europe GmbH Hagenauer Strasse 43, 65203 Wiesbaden, An Ghearmáin</p> <p>Ionadaí Údaraithe san AE : Panasonic Connect Europe GmbH Panasonic Testing Centre Winsbergring 15, 22525 Hamburg, An Ghearmáin</p>
Hrvatski	<p>Proizvodi: Panasonic Connect Co., Ltd. 4-1-62 Minoshima, Hakata-ku, Fukuoka 812-8531, Japan</p> <p>Uvoznik: Panasonic Connect Europe GmbH Hagenauer Strasse 43, 65203 Wiesbaden, Njemačka</p> <p>Ovlašteni zastupnik u EU-u: Panasonic Connect Europe GmbH Panasonic Testing Centre Winsbergring 15, 22525 Hamburg, Njemačka</p>
Íslenskur	<p>Framleitt af: Panasonic Connect Co., Ltd. 4-1-62, Minoshima, Hakata-ku, Fukuoka 812-8531, Japan</p> <p>Innflytjandi: Panasonic Connect Europe GmbH Hagenauer Strasse 43, 65203 Wiesbaden, Þýskalandi</p> <p>Viðurkenndur fulltrúi í ESB: Panasonic Connect Europe GmbH Panasonic Testing Centre Winsbergring 15, 22525 Hamburg, Þýskalandi</p>
Italiano	<p>Fabbricato da: Panasonic Connect Co., Ltd. 4-1-62 Minoshima, Hakata-ku, Fukuoka 812-8531, Giappone</p> <p>Importatore: Panasonic Connect Europe GmbH Hagenauer Strasse 43, 65203 Wiesbaden, Germania</p> <p>Rappresentante autorizzato nell'UE: Panasonic Connect Europe GmbH Panasonic Testing Centre Winsbergring 15, 22525 Amburgo, Germania</p>

Latviešu	<p>Ražotājs: Panasonic Connect Co., Ltd. 4-1-62 Minoshima, Hakata-ku, Fukuoka 812-8531, Japāna</p> <p>Importētājs: Panasonic Connect Europe GmbH Hagenauer Strasse 43, 65203 Wiesbaden, Vācija</p> <p>Oficiālais pārstāvis ES: Panasonic Connect Europe GmbH Panasonic Testing Centre Winsbergring 15, 22525 Hamburg, Vācija</p>
Lietuvių	<p>Gamintojas: Panasonic Connect Co., Ltd. 4-1-62 Minoshima, Hakata-ku, Fukuoka 812-8531, Japonija</p> <p>Importuotojas: Panasonic Connect Europe GmbH Hagenauer Strasse 43, 65203 Wiesbaden, Vokietija</p> <p>Igaliotasis atstovas ES: Panasonic Connect Europe GmbH Panasonic Testing Centre Winsbergring 15, 22525 Hamburgas, Vokietija</p>
Magyar	<p>Gyártotta: Panasonic Connect Co., Ltd. 4-1-62 Minoshima, Hakata-ku, Fukuoka 812-8531, Japán</p> <p>Importőr: Panasonic Connect Europe GmbH Hagenauer Strasse 43, 65203 Wiesbaden, Németország</p> <p>Hivatalos képviselő az EU-ban: Panasonic Connect Europe GmbH Panasonic Testing Centre Winsbergring 15, 22525 Hamburg, Németország</p>
Malti	<p>Manifatturat minn: Panasonic Connect Co., Ltd. 4-1-62 Minoshima, Hakata-ku, Fukuoka 812-8531, il-Gappun</p> <p>Importatur: Panasonic Connect Europe GmbH Hagenauer Strasse 43, 65203 Wiesbaden, il-Ġermanja</p> <p>Rappreżentant Awtorizzat fl-UE: Panasonic Connect Europe GmbH Panasonic Testing Centre Winsbergring 15, 22525 Hamburg, il-Ġermanja</p>
Nederlands	<p>Geproduceerd door: Panasonic Connect Co., Ltd. 4-1-62 Minoshima, Hakata-ku, Fukuoka 812-8531, Japan</p> <p>Importeur: Panasonic Connect Europe GmbH Hagenauer Strasse 43, 65203 Wiesbaden, Duitsland</p> <p>Bevoegde vertegenwoordiger in de EU: Panasonic Connect Europe GmbH Panasonic Testing Centre Winsbergring 15, 22525 Hamburg, Duitsland</p>
Norsk	<p>Produsert av: Panasonic Connect Co., Ltd. 4-1-62 Minoshima, Hakata-ku, Fukuoka 812-8531, Japan</p> <p>Importør: Panasonic Connect Europe GmbH Hagenauer Strasse 43, 65203 Wiesbaden, Tyskland</p> <p>Autorisert representant i EU: Panasonic Connect Europe GmbH Panasonic Testing Centre Winsbergring 15, 22525 Hamburg, Tyskland</p>
Polski	<p>Wyprodukowano przez: Panasonic Connect Co., Ltd. 4-1-62 Minoshima, Hakata-ku, Fukuoka 812-8531, Japonia</p> <p>Importer: Panasonic Connect Europe GmbH Hagenauer Strasse 43, 65203 Wiesbaden, Niemcy</p> <p>Upoważniony przedstawiciel w UE: Panasonic Connect Europe GmbH Panasonic Testing Centre Winsbergring 15, 22525 Hamburg, Niemcy</p>

Português	<p>Fabricado por: Panasonic Connect Co., Ltd. 4-1-62 Minoshima, Hakata-ku, Fukuoka 812-8531, Japão</p> <p>Importador: Panasonic Connect Europe GmbH Hagenauer Strasse 43, 65203 Wiesbaden, Alemanha</p> <p>Representante Autorizado na UE: Panasonic Connect Europe GmbH Panasonic Testing Centre Winsbergring 15, 22525 Hamburgo, Alemanha</p>
Română	<p>Fabricat de: Panasonic Connect Co., Ltd. 4-1-62 Minoshima, Hakata-ku, Fukuoka 812-8531, Japonia</p> <p>Importator: Panasonic Connect Europe GmbH Hagenauer Strasse 43, 65203 Wiesbaden, Germania</p> <p>Reprezentant autorizat în UE: Panasonic Connect Europe GmbH Panasonic Testing Centre Winsbergring 15, 22525 Hamburg, Germania</p>
Slovenčina	<p>Výrobca: Panasonic Connect Co., Ltd. 4-1-62 Minoshima, Hakata-ku, Fukuoka 812-8531, Japonsko</p> <p>Dovozca: Panasonic Connect Europe GmbH Hagenauer Strasse 43, 65203 Wiesbaden, Nemecko</p> <p>Autorizovaný zástupca v EÚ: Panasonic Connect Europe GmbH Panasonic Testing Centre Winsbergring 15, 22525 Hamburg, Nemecko</p>
Slovenščina	<p>Proizvajaja: Panasonic Connect Co., Ltd. 4-1-62 Minoshima, Hakata-ku, Fukuoka 812-8531, Japonska</p> <p>Uvoznik: Panasonic Connect Europe GmbH Hagenauer Strasse 43, 65203 Wiesbaden, Nemčija</p> <p>Pooblaščen zastonjnik v EU: Panasonic Connect Europe GmbH Panasonic Testing Centre Winsbergring 15, 22525 Hamburg, Nemčija</p>
Suomi	<p>Valmistaja: Panasonic Connect Co., Ltd. 4-1-62 Minoshima, Hakata-ku, Fukuoka 812-8531, Japani</p> <p>Maahantuojaja: Panasonic Connect Europe GmbH Hagenauer Strasse 43, 65203 Wiesbaden, Saksa</p> <p>Valtuutettu edustaja EU:ssa: Panasonic Connect Europe GmbH Panasonic Testing Centre Winsbergring 15, 22525 Hampuri, Saksa</p>
Svenska	<p>Tillverkad av: Panasonic Connect Co., Ltd. 4-1-62 Minoshima, Hakata-ku, Fukuoka 812-8531, Japan</p> <p>Importör: Panasonic Connect Europe GmbH Hagenauer Strasse 43, 65203 Wiesbaden, Tyskland</p> <p>Auktoriserad representant i EU: Panasonic Connect Europe GmbH Panasonic Testing Centre Winsbergring 15, 22525 Hamburg, Tyskland</p>
Türkçe	<p>Tarafından Üretilmiştir: Panasonic Connect Co., Ltd. 4-1-62 Minoshima, Hakata-ku, Fukuoka 812-8531, Japonya</p> <p>İthalatçı: Panasonic Connect Europe GmbH Hagenauer Strasse 43, 65203 Wiesbaden, Almanya</p> <p>AB Yetkili Temsilcisi: Panasonic Connect Europe GmbH Panasonic Testing Centre Winsbergring 15, 22525 Hamburg, Almanya</p>

Manufactured by: Panasonic Connect Co., Ltd.

4-1-62 Minoshima, Hakata-ku, Fukuoka 812-8531, Japan

Importer: Panasonic Connect Europe GmbH

Hagenauer Strasse 43, 65203 Wiesbaden, Germany

Authorized Representative in EU: Panasonic Connect Europe GmbH

Panasonic Testing Centre

Winsbergring 15, 22525 Hamburg, Germany

Importer for UK:

Panasonic Connect UK,

a branch of Panasonic Connect Europe GmbH,

Maxis 2, Western Road, Bracknell, Berkshire, RG12 1RT



Disposal of Old Equipment

Only for European Union and countries with recycling systems



This symbol on the products, packaging, and/or accompanying documents means that used electrical and electronic products must not be mixed with general household waste. For proper treatment, recovery and recycling of old products, please take them to applicable collection points in accordance with your national legislation.

By disposing of them correctly, you will help to save valuable resources and prevent any potential negative effects on human health and the environment.

For more information about collection and recycling, please contact your local authority.

Penalties may be applicable for incorrect disposal of this waste, in accordance with national legislation.

Product Information (for Turkey only)

AEEE Yönetmeliğine Uygundur.

Environment care information for users in China



This symbol is only valid in China.

Panasonic Connect Co., Ltd.

Web Site : <https://docs.connect.panasonic.com/projector>

© Panasonic Connect Co., Ltd. 2025

Panasonic Connect North America

Two Riverfront Plaza, Newark, NJ 07102

TEL: (877) 803 - 8492

Panasonic Canada Inc.

5770 Ambler Drive, Mississauga, Ontario L4W 2T3

TEL: (905) 624 - 5010

SS0225AM0 -PS
Printed in Japan

Appendix / Annexe / 付録

■ Projected image size and Projection distance ■ Taille de l'image projetée et distance de projection ■ 投写画面サイズと投写距離

Note

- When using projector models other than the following, refer to "Setting up" in the operating instructions of the projector. In addition, be sure to check the diagonal screen size SD (m), and use the "Projection distance formulas" ( Appendix page 5) to determine the projection distance (L).

PT-REQ15 / PT-REQ12 / PT-REQ10 / PT-REQ80 / PT-REZ15 / PT-REZ12 / PT-REZ10 / PT-REZ80

Remarque

- Lorsque vous utilisez des modèles de projecteur différents des modèles suivants, consultez "Installation" dans le mode d'emploi du projecteur. De plus, assurez-vous de vérifier la taille de l'écran en diagonale SD (m) et d'utiliser la "Formules de distance de projection" ( Annexe page 5) pour déterminer la distance de projection (L).

PT-REQ15 / PT-REQ12 / PT-REQ10 / PT-REQ80 / PT-REZ15 / PT-REZ12 / PT-REZ10 / PT-REZ80

お知らせ

- 下記以外のプロジェクターをご使用の場合は、プロジェクターの取扱説明書「設置する」をご覧ください。または、投写画面サイズ SD (m) をご確認のうえ、「投写距離計算式」( 付録 5 ページ) で投写距離 (L) を求めてください。

PT-REQ15J / PT-REQ12J / PT-REQ10J / PT-REZ15J / PT-REZ12J / PT-REZ10J / PT-REZ80J

The dimensions of the following table contain a slight error.

Periods are used to represent decimal points in the calculation formulas in the following table.

Les dimensions du tableau suivant peuvent présenter un léger écart.

Les points sont utilisés pour indiquer les décimales dans les formules de calcul dans le tableau suivant.

次の表内の寸法は若干の誤差があります。

Appendix / Annexe / 付録 (continued / suite / つづき)

- When the screen aspect ratio is 16:10
- Lorsque le rapport d'aspect de l'écran est 16:10
- 画面アスペクト比 16 : 10 のとき

(Unit / Unités / 単位 : m)

Throw ratio / Rapport de projection / スローレシオ : [3.30 - 6.60:1]					
SD	SH	SW	LW	LT	H
1.78 (70")	0.942	1.508	4.87	9.56	-0.09 - 1.04
2.03 (80")	1.077	1.723	5.62	11.12	-0.11 - 1.19
2.29 (90")	1.212	1.939	6.36	12.67	-0.12 - 1.33
2.54 (100")	1.346	2.154	7.11	14.23	-0.14 - 1.48
3.05 (120")	1.615	2.585	8.60	17.34	-0.16 - 1.78
3.81 (150")	2.019	3.231	10.84	22.00	-0.20 - 2.22
5.08 (200")	2.692	4.308	14.57	29.78	-0.27 - 2.96
6.35 (250")	3.365	5.385	18.30	37.55	-0.34 - 3.70
7.62 (300")	4.039	6.462	22.03	45.33	-0.40 - 4.44
8.89 (350")	4.712	7.539	25.76	53.11	-0.47 - 5.18
10.16 (400")	5.385	8.616	29.49	60.88	-0.54 - 5.92
12.70 (500")	6.731	10.770	36.95	76.43	-0.67 - 7.40
15.24 (600")	8.077	12.923	44.41	91.98	-0.81 - 8.89
17.78 (700")	9.423	15.077	51.87	107.54	-0.94 - 10.37
20.32 (800")	10.770	17.231	59.33	123.09	-1.08 - 11.85
22.86 (900")	12.116	19.385	66.79	138.64	-1.21 - 13.33
25.40 (1000")	13.462	21.539	74.25	154.19	-1.35 - 14.81

- When the screen aspect ratio is 16:9
- Lorsque le rapport d'aspect de l'écran est 16:9
- 画面アスペクト比 16 : 9 のとき

(Unit / Unités / 単位 : m)

Throw ratio / Rapport de projection / スローレシオ : [3.30 - 6.62:1]					
SD	SH	SW	LW	LT	H
1.78 (70")	0.872	1.550	5.02	9.86	-0.15 - 1.02
2.03 (80")	0.996	1.771	5.78	11.46	-0.17 - 1.16
2.29 (90")	1.121	1.992	6.55	13.06	-0.19 - 1.31
2.54 (100")	1.245	2.214	7.32	14.66	-0.21 - 1.45
3.05 (120")	1.494	2.657	8.85	17.86	-0.25 - 1.74
3.81 (150")	1.868	3.321	11.15	22.65	-0.31 - 2.18
5.08 (200")	2.491	4.428	14.98	30.64	-0.42 - 2.91
6.35 (250")	3.113	5.535	18.82	38.63	-0.52 - 3.63
7.62 (300")	3.736	6.641	22.65	46.63	-0.62 - 4.36
8.89 (350")	4.358	7.748	26.48	54.62	-0.73 - 5.09
10.16 (400")	4.981	8.855	30.32	62.61	-0.83 - 5.81
12.70 (500")	6.226	11.069	37.99	78.60	-1.04 - 7.26
15.24 (600")	7.472	13.283	45.65	94.58	-1.25 - 8.72
17.78 (700")	8.717	15.497	53.32	110.56	-1.45 - 10.17
20.32 (800")	9.962	17.710	60.99	126.55	-1.66 - 11.62
22.86 (900")	11.207	19.924	68.66	142.53	-1.87 - 13.08
25.40 (1000")	12.453	22.138	76.32	158.52	-2.08 - 14.53

Appendix / Annexe / 付録 (continued / suite / つづき)

- When the screen aspect ratio is 4:3
- Lorsque le rapport d'aspect de l'écran est 4:3
- 画面アスペクト比 4 : 3 のとき

(Unit / Unités / 単位 : m)

Throw ratio / Rapport de projection / スローレシオ : [3.98 - 8.01:1]					
SD	SH	SW	LW	LT	H
1.78 (70")	1.067	1.422	5.56	11.00	-0.11 - 1.17
2.03 (80")	1.219	1.626	6.40	12.76	-0.12 - 1.34
2.29 (90")	1.372	1.829	7.25	14.52	-0.14 - 1.51
2.54 (100")	1.524	2.032	8.09	16.28	-0.15 - 1.68
3.05 (120")	1.829	2.438	9.78	19.80	-0.18 - 2.01
3.81 (150")	2.286	3.048	12.32	25.08	-0.23 - 2.52
5.08 (200")	3.048	4.064	16.54	33.89	-0.31 - 3.35
6.35 (250")	3.810	5.080	20.76	42.69	-0.38 - 4.19
7.62 (300")	4.572	6.096	24.98	51.49	-0.46 - 5.03
8.89 (350")	5.334	7.112	29.21	60.29	-0.53 - 5.87
10.16 (400")	6.096	8.128	33.43	69.10	-0.61 - 6.71
12.70 (500")	7.620	10.160	41.87	86.70	-0.76 - 8.38
15.24 (600")	9.144	12.192	50.32	104.31	-0.91 - 10.06
17.78 (700")	10.668	14.224	58.77	121.91	-1.07 - 11.74
20.32 (800")	12.192	16.256	67.21	139.52	-1.22 - 13.41
22.86 (900")	13.716	18.288	75.66	157.13	-1.37 - 15.09
25.40 (1000")	15.240	20.320	84.10	174.73	-1.52 - 16.76

- When the screen aspect ratio is 21:9
- Lorsque le rapport d'aspect de l'écran est 21:9
- 画面アスペクト比 21 : 9 のとき

(Unit / Unités / 単位 : m)

Throw ratio / Rapport de projection / スローレシオ : [3.31 - 6.65:1]					
SD	SH	SW	LW	LT	H
1.78 (70")	0.691	1.638	5.32	10.50	-0.27 - 0.96
2.03 (80")	0.790	1.872	6.13	12.19	-0.31 - 1.10
2.29 (90")	0.889	2.106	6.94	13.88	-0.35 - 1.23
2.54 (100")	0.987	2.340	7.75	15.57	-0.38 - 1.37
3.05 (120")	1.185	2.808	9.37	18.95	-0.46 - 1.65
3.81 (150")	1.481	3.510	11.81	24.02	-0.58 - 2.06
5.08 (200")	1.975	4.681	15.86	32.47	-0.77 - 2.74
6.35 (250")	2.468	5.851	19.91	40.92	-0.96 - 3.43
7.62 (300")	2.962	7.021	23.96	49.37	-1.15 - 4.11
8.89 (350")	3.456	8.191	28.02	57.81	-1.34 - 4.80
10.16 (400")	3.949	9.361	32.07	66.26	-1.54 - 5.49
12.70 (500")	4.936	11.701	40.18	83.16	-1.92 - 6.86
15.24 (600")	5.924	14.042	48.28	100.06	-2.30 - 8.23
17.78 (700")	6.911	16.382	56.39	116.96	-2.69 - 9.60
20.32 (800")	7.898	18.722	64.49	133.85	-3.07 - 10.97
22.86 (900")	8.886	21.062	72.60	150.75	-3.46 - 12.34
25.40 (1000")	9.873	23.403	80.70	167.65	-3.84 - 13.71

Note

- A $\pm 5\%$ error in listed projection distances may occur.
When [GEOMETRY] is used, distance is corrected to become smaller than the specified image size.
- The throw ratio is based on the value during projection with the projected image size of 2.54 m (100").

Remarque

- Une erreur de $\pm 5\%$ dans des distances de projection énumérées peut se produire.
Lorsque [GÉOMÉTRIE] est utilisé, la distance est corrigée pour devenir inférieure à la taille d'image spécifiée.
- Le rapport de projection est basé sur la valeur en cours de projection avec une taille de l'image projetée de 2,54 m (100").

お知らせ

- 記載の投写距離は $\pm 5\%$ の誤差が発生します。
また、[幾何学歪補正] 使用時は、所定の画面サイズよりも小さくなる方向で補正されます。
- スローレシオは、投写画面サイズ 100 型投写時の値を基準にしています。

Setting-up dimensions which are not given in the above table can be calculated using the formulas below. Check the projected image size SD (m) and use the following formula to determine projection distance (L).

La configuration des dimensions qui ne sont pas données dans le tableau ci-dessus peut être calculée à l'aide des formules suivantes. Vérifiez la taille de l'image projetée SD (m) et utilisez la formule suivante pour déterminer la distance de projection (L).

上記の表以外の投写寸法は次の計算式で求めることができます。投写画面サイズ SD (m) をご確認のうえ、それぞれの計算式で投写距離 (L) を求めてください。

Appendix / Annexe / 付録 (continued / suite / つづき)

- Projection distance formulas
- Formules de distance de projection
- 投写距離計算式

Values obtained by the following calculation formulae contain a slight error.
 Periods are used to represent decimal points in the calculation formulas in the following table.

Les valeurs obtenues par les formules de calcul suivantes contiennent une légère erreur.
 Les points sont utilisés pour indiquer les décimales dans les formules de calcul dans le tableau suivant.

下記の計算式で求められる値には、若干の誤差があります。

(Unit / Unités / 単位 : m)

	L	
	LW	LT
When the screen aspect ratio is 16:10 Lorsque le rapport d'aspect de l'écran est 16:10 画面アスペクト比 16 : 10 のとき	=2.9370 × SD - 0.3521	=6.1227 × SD - 1.3252
When the screen aspect ratio is 16:9 Lorsque le rapport d'aspect de l'écran est 16:9 画面アスペクト比 16 : 9 のとき	=3.0187 × SD - 0.3521	=6.2929 × SD - 1.3252
When the screen aspect ratio is 4:3 Lorsque le rapport d'aspect de l'écran est 4:3 画面アスペクト比 4 : 3 のとき	=3.3249 × SD - 0.3521	=6.9314 × SD - 1.3252
When the screen aspect ratio is 21:9 Lorsque le rapport d'aspect de l'écran est 21:9 画面アスペクト比 21 : 9 のとき	=3.1911 × SD - 0.3521	=6.6524 × SD - 1.3252

Panasonic Connect Co., Ltd.

Web Site : <https://docs.connect.panasonic.com/projector>

Panasonic Connect North America

Two Riverfront Plaza, Newark, NJ 07102

TEL: (877) 803 - 8492

Panasonic Canada Inc.

5770 Ambler Drive, Mississauga, Ontario L4W 2T3

TEL: (905) 624 - 5010

パナソニック コネクト株式会社

〒 571-8503 大阪府門真市松葉町 2 番 15 号 電話 ☎ 0120-872-601