

This zoom lens is designed for use with Panasonic's applicable projectors.

*\*Please use the lens only on the specified Panasonic projector.*

### Specifications (Specifications subject to change without notice.)

F-number	1.9 - 2.5	
Focal distance (f)	58.3 mm - 115.6 mm [2 19/64 in - 4 35/64 in]	
Throw ratio	3.30 - 6.60:1 (16:10 aspect ratio)	
	3.30 - 6.62:1 (16:9 aspect ratio)	
	3.98 - 8.01:1 (4:3 aspect ratio)	
	3.31 - 6.65:1 (21:9 aspect ratio)	
Dimensions	Width	135 mm [5 5/16 in]
	Height	148 mm [5 13/16 in]
	Depth	254 mm [10 in]
Weight	Approx. 2.4 kg (Approx. 5.3 lbs)	
Applicable projector	PT-REQ15/PT-REQ12/PT-REQ10/PT-REQ80/PT-REZ15/PT-REZ12/PT-REZ10/PT-REZ80	

### Dimensions

unit : mm [inch]  
This illustration is not drawn to scale.

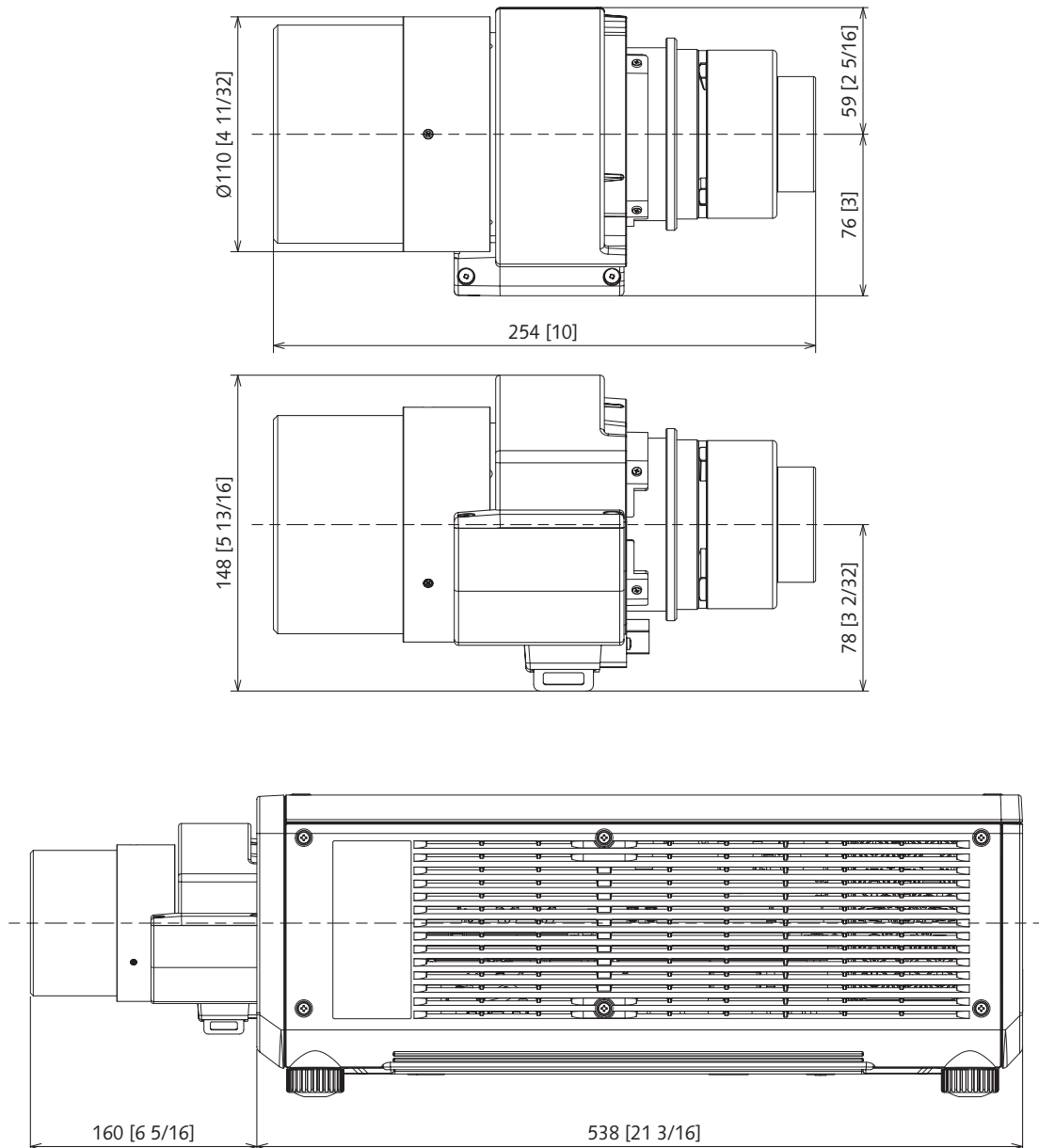

**Dimensional relationship diagram**

The dimensional relationship between the screen and the projector is shown below.

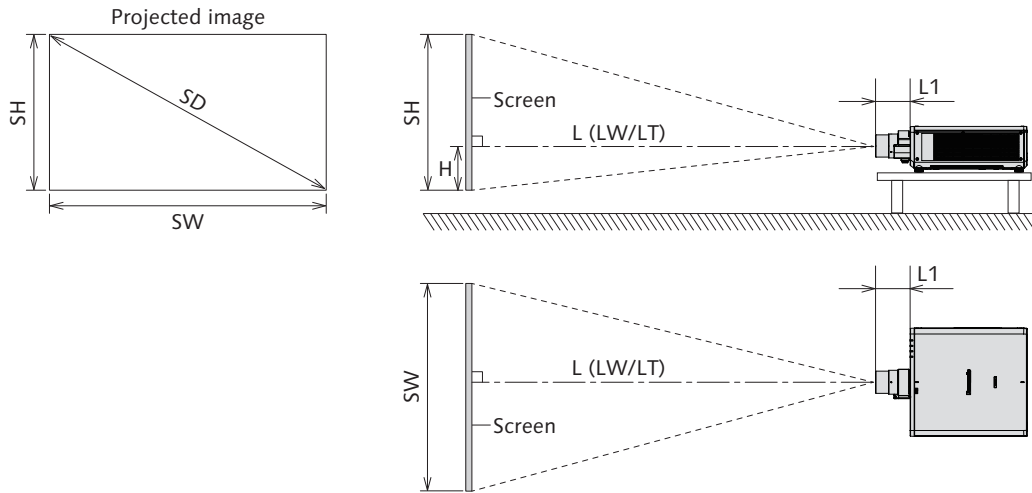

**Note**

- This illustration is prepared on the assumption that the projected image size and position have been aligned to fit full in the screen.
- This illustration is not drawn to scale.
- The values are approximate.

SH	Projected image height
SW	Projected image width
SD	Projected image size
H	Distance from the lens center to the bottom edge of the projected image
L	Projection distance (distance from the front end of the projection lens to the screen)
	LW Minimum projection distance when the Zoom Lens is used
	LT Maximum projection distance when the Zoom Lens is used
L1	Lens protrusion dimension (distance from the front surface of the projector to the front end of the projection lens)

Unit : m

Projector model	Dimension for L1 (approximate value)
PT-REQ15/PT-REQ12/PT-REQ10/PT-REQ80	0.160
PT-REZ15/PT-REZ12/PT-REZ10/PT-REZ80	

**Projection distance**

A ±5% error in listed projection distances may occur.

When [GEOMETRY] is used, distance is corrected to become smaller than the specified image size.

Screen aspect ratio 16:10

Unit: meters

Projector model			PT-REQ15/PT-REQ12/PT-REQ10/PT-REQ80 PT-REZ15/PT-REZ12/PT-REZ10/PT-REZ80		PT-REQ15/PT-REQ12/PT-REQ10/PT-REQ80 PT-REZ15/PT-REZ12/PT-REZ10/PT-REZ80		
Throw ratio			3.30 - 6.60:1				
Projected image size			Projection distance (L)		Height position (H)		
Diagonal (SD)		Height (SH)	Width (SW)	Min. (LW)			Max. (LT)
m	inches						
1.778	70	0.942	1.508	4.87	9.56	-0.09 - 1.04	
2.032	80	1.077	1.723	5.62	11.12	-0.11 - 1.19	
2.286	90	1.212	1.939	6.36	12.67	-0.12 - 1.33	
2.540	100	1.346	2.154	7.11	14.23	-0.14 - 1.48	
3.048	120	1.615	2.585	8.60	17.34	-0.16 - 1.78	
3.810	150	2.019	3.231	10.84	22.00	-0.20 - 2.22	
5.080	200	2.692	4.308	14.57	29.78	-0.27 - 2.96	
6.350	250	3.365	5.385	18.30	37.55	-0.34 - 3.70	
7.620	300	4.039	6.462	22.03	45.33	-0.40 - 4.44	
8.890	350	4.712	7.539	25.76	53.11	-0.47 - 5.18	
10.160	400	5.385	8.616	29.49	60.88	-0.54 - 5.92	
12.700	500	6.731	10.770	36.95	76.43	-0.67 - 7.40	
15.240	600	8.077	12.923	44.41	91.98	-0.81 - 8.89	
17.780	700	9.423	15.077	51.87	107.54	-0.94 - 10.37	
20.320	800	10.770	17.231	59.33	123.09	-1.08 - 11.85	
22.860	900	12.116	19.385	66.79	138.64	-1.21 - 13.33	
25.400	1000	13.462	21.539	74.25	154.19	-1.35 - 14.81	

• The throw ratio is based on the value during projection with the projected image size of 2.54 m [100 in]

Screen aspect ratio 16:10

Unit: feet

Projector model			PT-REQ15/PT-REQ12/PT-REQ10/PT-REQ80 PT-REZ15/PT-REZ12/PT-REZ10/PT-REZ80		PT-REQ15/PT-REQ12/PT-REQ10/PT-REQ80 PT-REZ15/PT-REZ12/PT-REZ10/PT-REZ80		
Throw ratio			3.30 - 6.60:1				
Projected image size			Projection distance (L)		Height position (H)		
Diagonal (SD)		Height (SH)	Width (SW)	Min. (LW)			Max. (LT)
m	inches						
1.778	70	3.092	4.947	15.98	31.37	-0.31 - 3.40	
2.032	80	3.533	5.653	18.42	36.47	-0.35 - 3.89	
2.286	90	3.975	6.360	20.87	41.57	-0.40 - 4.37	
2.540	100	4.417	7.067	23.32	46.67	-0.44 - 4.86	
3.048	120	5.300	8.480	28.21	56.88	-0.53 - 5.83	
3.810	150	6.625	10.600	35.56	72.19	-0.66 - 7.29	
5.080	200	8.833	14.133	47.80	97.70	-0.88 - 9.72	
6.350	250	11.042	17.667	60.03	123.21	-1.11 - 12.15	
7.620	300	13.250	21.200	72.27	148.72	-1.33 - 14.57	
8.890	350	15.458	24.733	84.51	174.23	-1.55 - 17.00	
10.160	400	17.667	28.267	96.75	199.74	-1.77 - 19.43	
12.700	500	22.083	35.333	121.22	250.77	-2.21 - 24.29	
15.240	600	26.500	42.400	145.70	301.79	-2.65 - 29.15	
17.780	700	30.917	49.467	170.17	352.81	-3.09 - 34.01	
20.320	800	35.333	56.533	194.65	403.83	-3.53 - 38.87	
22.860	900	39.750	63.600	219.12	454.86	-3.98 - 43.72	
25.400	1000	44.167	70.667	243.60	505.88	-4.42 - 48.58	

• The throw ratio is based on the value during projection with the projected image size of 2.54 m [100 in]

## Zoom Lens

Screen aspect ratio 16:9

Unit: meters

Projector model			PT-REQ15/PT-REQ12/PT-REQ10/PT-REQ80 PT-REZ15/PT-REZ12/PT-REZ10/PT-REZ80				PT-REQ15/PT-REQ12/PT-REQ10/PT-REQ80 PT-REZ15/PT-REZ12/PT-REZ10/PT-REZ80
Throw ratio			3.30 - 6.62:1				
Projected image size			Projection distance (L)			Height position (H)	
Diagonal (SD)		Height (SH)	Width (SW)	Min. (LW)	Max. (LT)		
m	inches						
1.778	70	0.872	1.550	5.02	9.86	-0.15 - 1.02	
2.032	80	0.996	1.771	5.78	11.46	-0.17 - 1.16	
2.286	90	1.121	1.992	6.55	13.06	-0.19 - 1.31	
2.540	100	1.245	2.214	7.32	14.66	-0.21 - 1.45	
3.048	120	1.494	2.657	8.85	17.86	-0.25 - 1.74	
3.810	150	1.868	3.321	11.15	22.65	-0.31 - 2.18	
5.080	200	2.491	4.428	14.98	30.64	-0.42 - 2.91	
6.350	250	3.113	5.535	18.82	38.63	-0.52 - 3.63	
7.620	300	3.736	6.641	22.65	46.63	-0.62 - 4.36	
8.890	350	4.358	7.748	26.48	54.62	-0.73 - 5.09	
10.160	400	4.981	8.855	30.32	62.61	-0.83 - 5.81	
12.700	500	6.226	11.069	37.99	78.60	-1.04 - 7.26	
15.240	600	7.472	13.283	45.65	94.58	-1.25 - 8.72	
17.780	700	8.717	15.497	53.32	110.56	-1.45 - 10.17	
20.320	800	9.962	17.710	60.99	126.55	-1.66 - 11.62	
22.860	900	11.207	19.924	68.66	142.53	-1.87 - 13.08	
25.400	1000	12.453	22.138	76.32	158.52	-2.08 - 14.53	

• The throw ratio is based on the value during projection with the projected image size of 2.54 m [100 in]

Screen aspect ratio 16:9

Unit: feet

Projector model			PT-REQ15/PT-REQ12/PT-REQ10/PT-REQ80 PT-REZ15/PT-REZ12/PT-REZ10/PT-REZ80				PT-REQ15/PT-REQ12/PT-REQ10/PT-REQ80 PT-REZ15/PT-REZ12/PT-REZ10/PT-REZ80
Throw ratio			3.30 - 6.62:1				
Projected image size			Projection distance (L)			Height position (H)	
Diagonal (SD)		Height (SH)	Width (SW)	Min. (LW)	Max. (LT)		
m	inches						
1.778	70	2.860	5.084	16.45	32.36	-0.48 - 3.34	
2.032	80	3.268	5.811	18.97	37.61	-0.54 - 3.81	
2.286	90	3.677	6.537	21.48	42.85	-0.61 - 4.29	
2.540	100	4.086	7.263	24.00	48.09	-0.68 - 4.77	
3.048	120	4.903	8.716	29.03	58.58	-0.82 - 5.72	
3.810	150	6.128	10.895	36.58	74.31	-1.02 - 7.15	
5.080	200	8.171	14.526	49.16	100.53	-1.36 - 9.53	
6.350	250	10.214	18.158	61.73	126.76	-1.70 - 11.92	
7.620	300	12.257	21.789	74.31	152.98	-2.04 - 14.30	
8.890	350	14.299	25.421	86.89	179.20	-2.38 - 16.68	
10.160	400	16.342	29.053	99.47	205.42	-2.72 - 19.06	
12.700	500	20.428	36.316	124.62	257.86	-3.41 - 23.83	
15.240	600	24.513	43.579	149.78	310.30	-4.08 - 28.60	
17.780	700	28.599	50.842	174.93	362.74	-4.77 - 33.37	
20.320	800	32.684	58.105	200.09	415.18	-5.45 - 38.13	
22.860	900	36.770	65.368	225.25	467.62	-6.13 - 42.90	
25.400	1000	40.855	72.631	250.40	520.06	-6.81 - 47.66	

• The throw ratio is based on the value during projection with the projected image size of 2.54 m [100 in]

Screen aspect ratio 4:3

Unit: meters

Projector model			PT-REQ15/PT-REQ12/PT-REQ10/PT-REQ80 PT-REZ15/PT-REZ12/PT-REZ10/PT-REZ80				PT-REQ15/PT-REQ12/PT-REQ10/PT-REQ80 PT-REZ15/PT-REZ12/PT-REZ10/PT-REZ80
Throw ratio			3.98 - 8.01:1				
Projected image size			Projection distance (L)				Height position (H)
Diagonal (SD)		Height (SH)	Width (SW)	Min. (LW)	Max. (LT)		
m	inches						
1.778	70	1.067	1.422	5.56	11.00	-0.11 - 1.17	
2.032	80	1.219	1.626	6.40	12.76	-0.12 - 1.34	
2.286	90	1.372	1.829	7.25	14.52	-0.14 - 1.51	
2.540	100	1.524	2.032	8.09	16.28	-0.15 - 1.68	
3.048	120	1.829	2.438	9.78	19.80	-0.18 - 2.01	
3.810	150	2.286	3.048	12.32	25.08	-0.23 - 2.52	
5.080	200	3.048	4.064	16.54	33.89	-0.31 - 3.35	
6.350	250	3.810	5.080	20.76	42.69	-0.38 - 4.19	
7.620	300	4.572	6.096	24.98	51.49	-0.46 - 5.03	
8.890	350	5.334	7.112	29.21	60.29	-0.53 - 5.87	
10.160	400	6.096	8.128	33.43	69.10	-0.61 - 6.71	
12.700	500	7.620	10.160	41.87	86.70	-0.76 - 8.38	
15.240	600	9.144	12.192	50.32	104.31	-0.91 - 10.06	
17.780	700	10.668	14.224	58.77	121.91	-1.07 - 11.74	
20.320	800	12.192	16.256	67.21	139.52	-1.22 - 13.41	
22.860	900	13.716	18.288	75.66	157.13	-1.37 - 15.09	
25.400	1000	15.240	20.320	84.10	174.73	-1.52 - 16.76	

• The throw ratio is based on the value during projection with the projected image size of 2.54 m [100 in]

Screen aspect ratio 4:3

Unit: feet

Projector model			PT-REQ15/PT-REQ12/PT-REQ10/PT-REQ80 PT-REZ15/PT-REZ12/PT-REZ10/PT-REZ80				PT-REQ15/PT-REQ12/PT-REQ10/PT-REQ80 PT-REZ15/PT-REZ12/PT-REZ10/PT-REZ80
Throw ratio			3.98 - 8.01:1				
Projected image size			Projection distance (L)				Height position (H)
Diagonal (SD)		Height (SH)	Width (SW)	Min. (LW)	Max. (LT)		
m	inches						
1.778	70	3.500	4.667	18.24	36.09	-0.35 - 3.85	
2.032	80	4.000	5.333	21.01	41.86	-0.40 - 4.40	
2.286	90	4.500	6.000	23.78	47.64	-0.45 - 4.95	
2.540	100	5.000	6.667	26.55	53.41	-0.50 - 5.50	
3.048	120	6.000	8.000	32.09	64.97	-0.60 - 6.60	
3.810	150	7.500	10.000	40.41	82.29	-0.75 - 8.25	
5.080	200	10.000	13.333	54.26	111.18	-1.00 - 11.00	
6.350	250	12.500	16.667	68.11	140.06	-1.25 - 13.75	
7.620	300	15.000	20.000	81.97	168.94	-1.50 - 16.50	
8.890	350	17.500	23.333	95.82	197.82	-1.75 - 19.25	
10.160	400	20.000	26.667	109.68	226.70	-2.00 - 22.00	
12.700	500	25.000	33.333	137.38	284.46	-2.50 - 27.50	
15.240	600	30.000	40.000	165.09	342.22	-3.00 - 33.00	
17.780	700	35.000	46.667	192.80	399.98	-3.50 - 38.50	
20.320	800	40.000	53.333	220.51	457.74	-4.00 - 44.00	
22.860	900	45.000	60.000	248.22	515.51	-4.50 - 49.50	
25.400	1000	50.000	66.667	275.92	573.27	-5.00 - 55.00	

• The throw ratio is based on the value during projection with the projected image size of 2.54 m [100 in]

Screen aspect ratio 21:9

Unit: meters

Projector model			PT-REQ15/PT-REQ12/PT-REQ10/PT-REQ80 PT-REZ15/PT-REZ12/PT-REZ10/PT-REZ80			PT-REQ15/PT-REQ12/PT-REQ10/PT-REQ80 PT-REZ15/PT-REZ12/PT-REZ10/PT-REZ80
Throw ratio			3.31 - 6.65:1			
Projected image size			Projection distance (L)			Height position (H)
Diagonal (SD)		Height (SH)	Width (SW)	Min. (LW)	Max. (LT)	
m	inches					
1.778	70	0.691	1.638	5.32	10.50	-0.27 - 0.96
2.032	80	0.790	1.872	6.13	12.19	-0.31 - 1.10
2.286	90	0.889	2.106	6.94	13.88	-0.35 - 1.23
2.540	100	0.987	2.340	7.75	15.57	-0.38 - 1.37
3.048	120	1.185	2.808	9.37	18.95	-0.46 - 1.65
3.810	150	1.481	3.510	11.81	24.02	-0.58 - 2.06
5.080	200	1.975	4.681	15.86	32.47	-0.77 - 2.74
6.350	250	2.468	5.851	19.91	40.92	-0.96 - 3.43
7.620	300	2.962	7.021	23.96	49.37	-1.15 - 4.11
8.890	350	3.456	8.191	28.02	57.81	-1.34 - 4.80
10.160	400	3.949	9.361	32.07	66.26	-1.54 - 5.49
12.700	500	4.936	11.701	40.18	83.16	-1.92 - 6.86
15.240	600	5.924	14.042	48.28	100.06	-2.30 - 8.23
17.780	700	6.911	16.382	56.39	116.96	-2.69 - 9.60
20.320	800	7.898	18.722	64.49	133.85	-3.07 - 10.97
22.860	900	8.886	21.062	72.60	150.75	-3.46 - 12.34
25.400	1000	9.873	23.403	80.70	167.65	-3.84 - 13.71

• The throw ratio is based on the value during projection with the projected image size of 2.54 m [100 in]

Screen aspect ratio 21:9

Unit: feet

Projector model			PT-REQ15/PT-REQ12/PT-REQ10/PT-REQ80 PT-REZ15/PT-REZ12/PT-REZ10/PT-REZ80			PT-REQ15/PT-REQ12/PT-REQ10/PT-REQ80 PT-REZ15/PT-REZ12/PT-REZ10/PT-REZ80
Throw ratio			3.31 - 6.65:1			
Projected image size			Projection distance (L)			Height position (H)
Diagonal (SD)		Height (SH)	Width (SW)	Min. (LW)	Max. (LT)	
m	inches					
1.778	70	2.267	5.375	17.46	34.46	-0.88 - 3.15
2.032	80	2.591	6.142	20.12	40.00	-1.01 - 3.60
2.286	90	2.915	6.910	22.78	45.55	-1.14 - 4.05
2.540	100	3.239	7.678	25.44	51.09	-1.26 - 4.50
3.048	120	3.887	9.214	30.76	62.18	-1.51 - 5.40
3.810	150	4.859	11.517	38.73	78.81	-1.89 - 6.75
5.080	200	6.478	15.356	52.03	106.53	-2.52 - 9.00
6.350	250	8.098	19.195	65.33	134.24	-3.15 - 11.25
7.620	300	9.718	23.034	78.62	161.96	-3.78 - 13.50
8.890	350	11.337	26.873	91.92	189.68	-4.41 - 15.74
10.160	400	12.957	30.712	105.22	217.40	-5.04 - 18.00
12.700	500	16.196	38.390	131.81	272.84	-6.30 - 22.49
15.240	600	19.435	46.068	158.40	328.27	-7.56 - 26.99
17.780	700	22.674	53.746	184.99	383.71	-8.82 - 31.49
20.320	800	25.913	61.424	211.59	439.15	-10.08 - 35.99
22.860	900	29.153	69.102	238.18	494.58	-11.34 - 40.49
25.400	1000	32.392	76.780	264.77	550.02	-12.60 - 44.99

• The throw ratio is based on the value during projection with the projected image size of 2.54 m [100 in]

### Calculation of the projection distance

To use a projected image size not listed in this manual, check the projected image size SD (m) and use the respective formula to calculate the value.

The unit of all the formulae is m. (Values obtained by the following calculation formulae contain a slight error.)

When calculating the value using image size designation (value in inches), multiply the value in inches by 0.0254 and substitute it into SD in the formula.

#### Screen aspect ratio 16:10

Unit: m

Projector model	Projection distance (L) formula	
	Min. (LW)	Max. (LT)
PT-REQ15/PT-REQ12/PT-REQ10/PT-REQ80	$=2.9370 \times SD - 0.3521$	$=6.1227 \times SD - 1.3252$
PT-REZ15/PT-REZ12/PT-REZ10/PT-REZ80		

#### Screen aspect ratio 16:9

Unit: m

Projector model	Projection distance (L) formula	
	Min. (LW)	Max. (LT)
PT-REQ15/PT-REQ12/PT-REQ10/PT-REQ80	$=3.0187 \times SD - 0.3521$	$=6.2929 \times SD - 1.3252$
PT-REZ15/PT-REZ12/PT-REZ10/PT-REZ80		

#### Screen aspect ratio 4:3

Unit: m

Projector model	Projection distance (L) formula	
	Min. (LW)	Max. (LT)
PT-REQ15/PT-REQ12/PT-REQ10/PT-REQ80	$=3.3249 \times SD - 0.3521$	$=6.9314 \times SD - 1.3252$
PT-REZ15/PT-REZ12/PT-REZ10/PT-REZ80		

#### Screen aspect ratio 21:9

Unit: m

Projector model	Projection distance (L) formula	
	Min. (LW)	Max. (LT)
PT-REQ15/PT-REQ12/PT-REQ10/PT-REQ80	$=3.1911 \times SD - 0.3521$	$=6.6524 \times SD - 1.3252$
PT-REZ15/PT-REZ12/PT-REZ10/PT-REZ80		

**Adjustment range by the lens position shift (optical shift)**

Based on the standard projection position using the optical axis shift function, the projection position can be adjusted in the range shown in the following figure.

Following figure shows the adjustment range when the projector is installed on the floor.

Projector model	PT-REQ15/PT-REQ12/PT-REQ10/PT-REQ80/PT-REZ15/PT-REZ12/PT-REZ10/PT-REZ80 is mounted.
Lens shift range	



[GEOMETRY] projection range

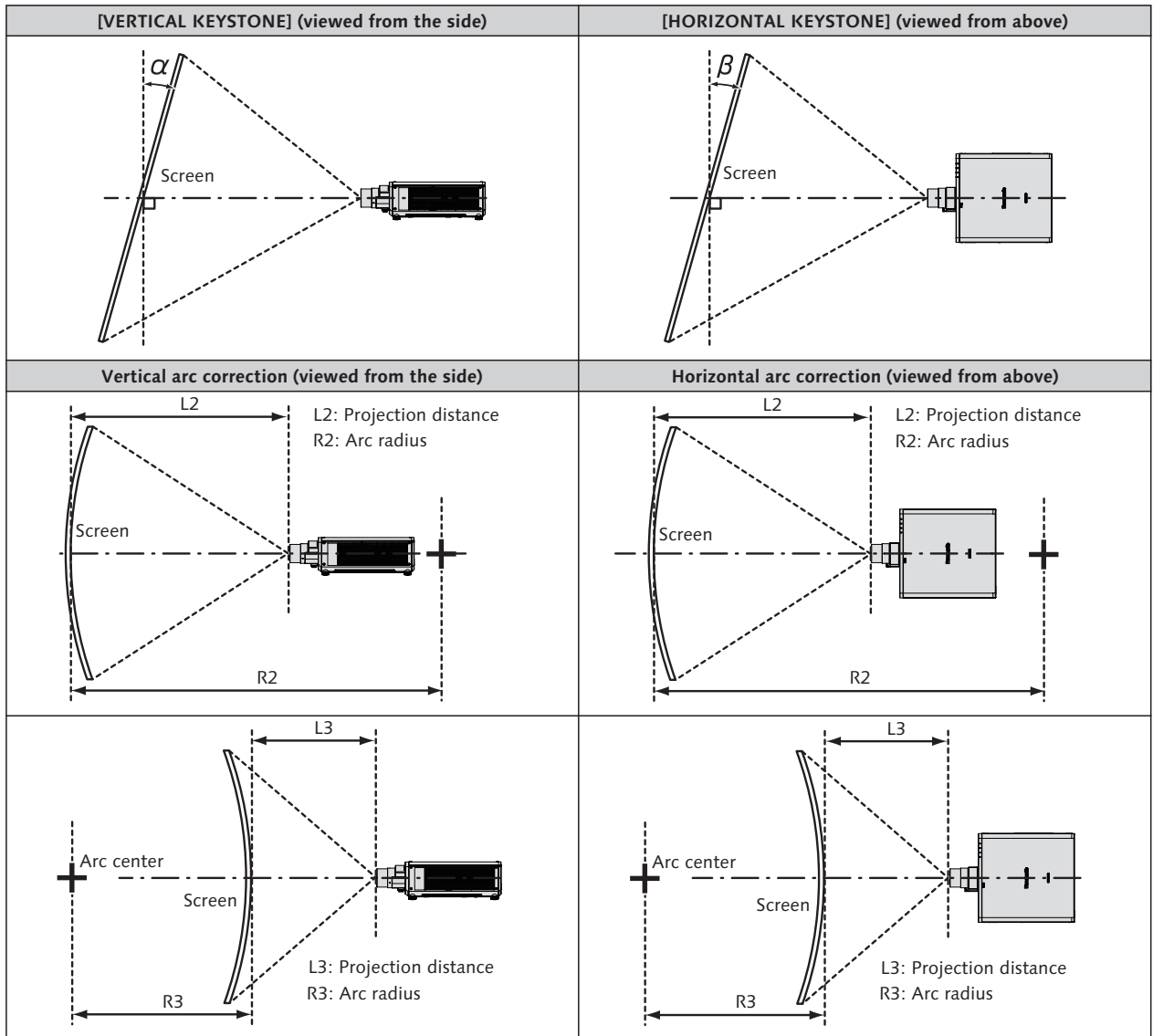

Projector model	Only [KEYSTONE] used <sup>1</sup>		[KEYSTONE] and [CURVED CORRECTION] used together				Only [CURVED CORRECTION] used	
	Vertical keystone correction angle $\alpha$ (°)	Horizontal keystone correction angle $\beta$ (°)	Vertical keystone correction angle $\alpha$ (°)	Horizontal keystone correction angle $\beta$ (°)	Min. value of R2/L2	Min. value of R3/L3	Min. value of R2/L2	Min. value of R3/L3
PT-REQ15 PT-REQ12 PT-REQ10 PT-REQ80	±40	±40	±20	±15	0.5	1.0	0.3	0.6
PT-REZ15 PT-REZ12 PT-REZ10 PT-REZ80								

<sup>1</sup> When [VERTICAL KEYSTONE] and [HORIZONTAL KEYSTONE] are used simultaneously, correction cannot be made exceeding total of 55°.

**Note**

- When [GEOMETRY] is used, the focus of the entire screen may be lost as correction increases.
- Make the curved screen a circular arc shape with one part of a perfect circle removed.
- Adjustment range of the [GEOMETRY] items may not match the listed projection range depending on the projection lens. Use this projector within the projection range, otherwise the correction may not work.